



# AXRX-QDM Receiver User and Programming Guide



**Wave Central LLC**  
**99 Garden Parkway, Suite C., Carlisle, PA 17013**  
**+1 888 736 9283** [www.wavecentralrf.com](http://www.wavecentralrf.com)

Rev 2  
January 2020

# WARNING



**The HD/SDI Video input connector is 75 Ohms. Make sure that the video cable(s) are fitted with 75 Ohm connectors. The illustration on the right is the correct BNC connector. Failure to do so will damage the BNC connector on the Pico and Pico Plus transmitters. The customer is liable for any damages for not adhering to this practice.**

# 1. Systems Description

This User Guide is about:

Equipment Title	Operational Frequencies
AXRX-QDM Diversity Receiver	2GHz to 5.8GHz
Compact Sector Antennas	2GHz to 5.8GHz



**Figure 1-1 – AXRX-QDM Receiver**

## 1.1 What is the AXRX-QDM Receiver?

The AXRX-QDM Receiver from WaveCentral is a feature-rich COFDM digital video receiver, which can operate in a variety of transmission bandwidths enabling the user to trade off image quality against range, to suit all types of missions.

The AXRX-QDM Receiver has Wave Central at its core and is ideal for establishing long duration rugged wireless video links, in harsh external environments, like mobile and urban environments. The AXRX-QDM receiver is available in a variety of frequency bands.

Control is achieved through a front panel interface or by connecting the unit to an IP network using the Ethernet interface given. You can quickly configure the device in the field with laptop PC and configuration software.

The product can be used with an optional external chargeable battery pack; IDX or Anton Bauer, providing between four and five hours battery life. The unit can also run from an external DC supply which is included.

The front panel allows the user to switch channels and do basic configuration without the need for connection to a PC, making it ideal for portable or mobile situations.

---

## What are the Key Features of the AXRX-QDM Receiver?

- Small dimensions: 5.7 x 3.5 x 1.6 inches (without cables or battery)
- Low power
- Fully featured 8/7/6/MHz demodulation
- Maximum ratio combining antenna diversity
- IP video streaming (RTSP and UDP) \*
- Ethernet control
- Front Panel control

### Specifications:

RF input (2) 2GHz to 5.8GHz

DVB-T Bandwidth 6, 7 & 8 MHz

DVB-T Guard Intervals 1/32, 1/16, 1/8 and 1/4

DVB-T FEC 1/2, 2/3, 3/4, 5/6 & 7/8

DVB T Constellations QPSK, 16QAM & 64QAM

Sensitivity <95dB

Video Line Standard PAL/NTSC

Resolutions (HD) 1920X1080i/59.94/50Hz  
1920X1080p 30/29.97/25/24/23.97  
1920X1080psf 30/29.97/25/24/23.97  
1280x720p 60/59.94/50Hz  
(SD) 720X480i/59.94Hz  
720X576i/50Hz

Video Out (2) SD/HD SDI Video (1) Composite – 75 Ohm BNC

Audio Out Analog (2) Stereo Line level via LEMO 5-pin OB, Headset Monitor  
Embedded

Power – DC Input 9 to 16VDC

Power Consumption 20 Watts

Available Battery Plates IDX or Anton Bauer

---

## 1.2 What are the Features and Benefits of AXRX-QDM Receivers?

It can be very useful to understand how the features of the unit yield tangible benefits to you. This table summarizes these features and, more importantly, the benefits.

### 1.2.1 Features and Benefits Table

Key Features	Key Benefits
Compliant DVB-T Demodulator and proprietary narrowband. Full Demodulation 8, 7, and 6 MHz	Correct multi-mode operation - Perfect integration with your current equipment.
Line Level Audio / Video Out, Headphone output.	Easy to use - Operations staff can use known standard equipment.
Digital COFDM Modulation	Excellent performance - Resistant to multipath interference, delivers high quality video and audio, also when mobile or in built up areas like urban environments.

Low Delay, high quality video encoding in MPEG-2 and MPEG-4	High reliability - Use a radio system like it was a line. You can select between MPEG 2 and 4 to suit your operation.
Low latency	Enables real-time operations like remote vehicle control or UAV operations.
Sixteen Presets Available	Better use of assets and resources - You can preset frequencies into sixteen presets. Configure the full operation in the calm of the headquarters then the operations staff only have to quickly select the preset with one button.
High reliability and availability	Reduced maintenance requirement, reduced spares holding, resulting in important cost benefits across the life of the system.
Low Mass	Applicable for discrete operation in the field.

**Note:** AXRX-QDM Receivers are frequency specified because they have internal down converters.

### 1.3 Getting an Overview of the AXRX-QDM Receiver

Diagram: AXRX-QDM Receiver Primary System

Figure 1-2 Primary System Layout

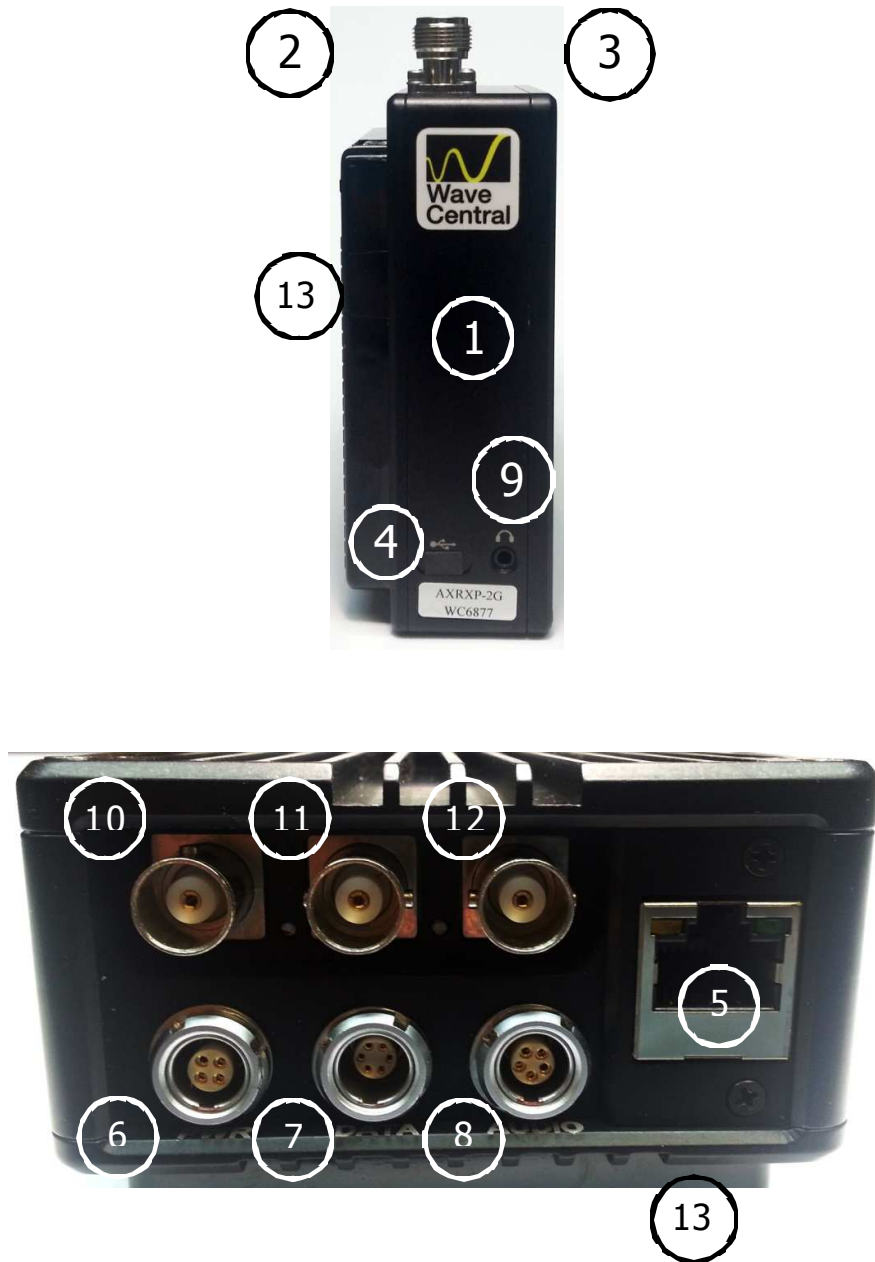

Primary Unit bottom panel shown

---

No	Item	Function
1	AXRX-QDM Receiver.	Primary Unit bottom panel shown.
2	N Connector 2-way female for antenna	Antennas connect here. Do not tighten too much – tighten with your hand.
3	N Connector 2-way female for antenna	Two antennas used for diversity reception.
4	USB Mini-B 5-way receptacle	Connects to your PC for programming the AXRX-QDM receiver.
5	RJ45 8-way receptacle (sockets).	Connects from your PC.
6	LEMO OB 4-way receptacle (sockets)	Power Input.
7	LEMO OB 6-way receptacle (sockets),	For control/data in and out.
8	LEMO OB 5-way receptacle (sockets).	Audio output.
9	1/8" Stereo Phone Jack	Headset audio monitoring
10	BNC - 75 Ohms chassis mount	SD/HD SDI
11	BNC - 75 Ohms chassis mount	SD/HD SDI
12	BNC - 75 Ohms chassis mount	For analog video output.
13	Battery Adapter Plate	IDX or Anton Bauer

**Table 1-3 – Primary System Diagram Key**

## 2. Getting Started

### 2.1 Identifying your Device

The AXRX-QDM Receiver is described in this User Guide.



**Figure 2-1 – AXRX-QDM Receiver showing Control Panel**

This is a AXRX-QDM Receiver [Quick Depby Min]  
Its type designation is: AXRX-QDM  
Dimensions: 5.7" (L) x 3.5" (W) x 1.6" (D)  
Less cables and battery adapter plate  
Weight: 1.4 pounds  
Operating Temperature: -10 degrees C to +45 degrees C  
Power Consumption: 8W. DC Input 6 to 16VDC

### 2.2 About the Labels on your AXRX-QDM Receiver

Which model do I have? What is its **Serial Number**?

This topic contains information covering placards, labels, markings, etc., showing the part number, legend and location of each placard, label, or marking required for safety or maintenance important information.

---



## Step 1: Identify the Device Label



**Figure 2-2 – AXRX-QDM Receiver Label**

No	Item
1	AXRXP-2G family of products.
2	Frequency range, 2GHz in this example.
3	WC with four digit serial number. This number will be necessary during a support call.

**Table 2-3 – AXRX-QDM Receiver Label Key**

## 2.3 Planning the Hardware Installation

During the layout of the system, you must give careful consideration of the location of this and all other related modules. Some of the items to think about include:

- Space - Keep 100mm clearance left and right for cable bending.
- How near to other devices (for example, source equipment).
- Length of cables.
- Environmental conditions (temperature, humidity, etc.)
- Access for repair.

## 2.4 About the Software with your AXRX-QDM Receiver

The AXRX-QDM Receiver has **two** software elements:

- **Firmware** that operates on the primary board of the device.
  - **Control Application** that you operate on your Windows PC.
-

## About the Firmware

Although much of the unit is built up of hardware components, many of the sophisticated features are done in the firmware operating on a Field Programmable Gate Array (FPGA) in the device.

When you must do an internal software upgrade we can give you an installer which contains all the code to do this easily.

## About the Control Application

The software tools give users with a convenient access to the most usual features and functions of the Device. All software tools are implemented as a web interface. The advantage of a web interface is that it is independent from the user's operating system and it is not necessary to have special software on the host PC.

The computer display control application of the unit gives access to many of the features of the radio but for more sophisticated operations and configuration tasks you'll connect up a PC operating a web browser to access the Control Pages on your AXRX-QDM Receiver.

The Control Page enables you to set up sixteen presets in the radio and have control of many parameters of the unit.

Here's what the receiver's Control Pages look like:

## Screenshot: AXRX-QDM Receiver Control Pages

The screenshot shows the NanoVue web interface for the AXRX-QDM Receiver. The interface is titled "NanoVue" and features the COBHAM logo in the top right corner. Below the title, the preset name "Solo-01" is displayed. The main navigation bar includes tabs for "Status", "Global Settings", "Configuration", "Log", "Uploads", and "Information". The "Configuration" tab is active, and a sub-menu at the top shows 16 numbered tabs, with tab 1 selected. The configuration page is divided into three main sections: "Demod", "Decoder", and "Encryption".

Section	Parameter	Value
Demod	Preset Name	Config 1
	Frequency	2405 MHz
	Bandwidth	2.5MHz
	Guard Interval	1/16
	Polarity	Normal
Mode		<input checked="" type="radio"/> Narrowband <input type="radio"/> DVB-T
Decoder	Decoder Input	Demod In
	MPEG-2 Decoder	Low Delay
	Service Name	Solo-01
Program Number	1	
Encryption	Decryption Mode	Off
	Decryption Keys	<a href="#">Change Keys</a>

At the bottom of the configuration page, there are "Save" and "Apply" buttons on the left, and a "Restore Defaults" button on the right.

Figure 2-4 – AXRX-QDM Receiver Control Pages

# 3. Controls, Connections and Indicators

## 3.1 About Controls, Connections and Indicators

You must find all the **controls** and **connections** on the unit. You also must identify and interpret **alarms** or **indicators**. These topics will help you identify all these features.

The device has **front** and **rear** panels which contain all the interface connections for the units and the controls and indicators.

The front panel contains the **control functions** used for in-field configuration and all connections are installed on the rear panel.

## 3.2 Exploring the Front Panel

Diagram: Front Panel



**Figure 3-1 AXRX-QDM Receiver Front Panel**

No	Item	Used for...
1	Power Switch	Power the receiver
2	Cancel Button	Each time you push the Cancel button the Field Controller steps up one menu level.
3	Navigation Button.	Push the Navigation button in to select menus or options. Move the Navigation button up and down to move between menus or change options. Move the Navigation button left and right to select numbers/letters when editing values.
4	Two line OLED display .	User interface.

**Table 3-2 – AXRX-QDM Receiver Front Panel Key**

## 3.3 Exploring the Control Panel

The control panel is presented as a Field Controller and is on the front panel of the AXRX-QDM receiver.

### 3.3.1 Field Controller Operation

The unit has a simple to use two button control system which has been designed for use in the field where it can be necessary to make adjustments to the AXRX-QDM Receiver settings quickly and easily. An in-depth description on how to operate the Field Controller and navigate through the units settings is given later in this guide.

### 3.3.2 Alarm System

The Field Controller can be setup to show a flashing **Low Battery** alarm when the voltage reaches a user-specified minimum level. There are no other visual or audible alarms on the AXRX-QDM Receiver.

---

## 4. Setting up your AXRX-QDM Receiver

### 4.1 Connecting the Antennas

This topic describes connecting systems designed mainly for sending the RF signals. Of all the variables affecting single-channel radio communications, the one item which an operator has the most control is the antenna. With the right antenna, an operator can change a marginal net into a reliable net.

There are two antenna interfaces on the rear panel of the AXRX-QDM receiver. Antenna one and two **must** be attached for optimum operation.

**CAUTION:** Antennas must be connected **directly** to the unit. If you have to use cables between the antennas and the receiver (in a mobile situation for example), keep them short and use very high quality cable.

#### Before you Start

This is necessary:

- Two Compact Sector antennas that align with the frequency range of your AXRX-QDM receiver.

#### Step 1: Attach the Antennas

1. Connect the antennas to the N connector receptacles on the top panel of the AXRX-QDM receiver.
2. Do not tighten the antennas too much – tighten with your hand.

#### Step 2: Set Antenna Polarization

1. COFDM links are very robust and are tolerant to changes in antenna location, but, it is important to try and keep the antennas in the **same plane** if possible.
2. The antennas used with the COFDM links are usually **vertically** polarized.
3. The Compactor antennas beam width azimuth of 110 degrees and a elevation beam width of 18 degrees, as exemplified for 2 GHz operation.
4. Rotation of the antennas should be directed toward the transmitter.

#### Next Steps

Connect the DC Power.

---

## 4.1 Connecting the DC Power

The AXRX-QDM receiver requires 12VDC. This can be supplied from a vehicle, an AC Adaptor or a battery pack.

### Before you Start

This is necessary:

- A 12VDC Power Source
- A AXRX-QDM receiver

### Step 1: Connect the DC Power

1. Connect a fully charged battery IDX or Anton Bauer to the battery adapter plate

### Next Steps

Connect Video and Audio Signals.

## 4.2 Connecting AC Power

### Before you Start

This is necessary:

- A 12V AC Adapter
- AXRX-QDM receiver.

### Step 1: Connect the AC Power

1. Connect the **LEMO OB 4-way plug** (pins) from the AC adaptor to the **LEMO OB 4-way receptacle** (sockets) on the AXRX-QDM receiver which is on the bottom panel.
2. Connect AC mains plug to your **local AC supply** and switch on.

### Next Steps

Connect Video Signals.

## 4.3 Connecting Video Signals

There are three video outputs on this unit:

- Composite Video (monitoring)– BNC 75 Ohms
  - SD/HD SDI– BNC 75 Ohms, output 1
  - SD/HD SDI– BNC 75 Ohms, output 2
-

## 4.4 Connecting Audio Signals

### Before you Start

This is necessary:

- AXRX-QDM receiver.
- LEMO 5-way plug harness with 2 female XLR connectors.
- Two audio monitors.
- Head phones to monitor audio at the receiver.

### Step 1: Connect Audio Signal

1. Connect the LEMO OB 5-way plug to the AV receptacle of the AXRX-QDM receiver.
2. Connect the XLR 3-way plugs to the audio mixer.
3. Switch on and tune the receiver to a transmission carrying audio.
4. Your audio will be heard at the audio mixer.
5. Connect headset into 1/8" Stereo jack on the side of the receiver.
6. Your audio will be heard on the headset.

## 4.5 Connecting Data Signals

### Before you Start

This is necessary:

- AXRX-QDM receiver
- Data Cable Assembly (optional)
- A PC or other data monitoring device.

### Step 1: Connect Data Signal

1. Connect the LEMO 6-way plug to the DATA receptacle of the AXRX-QDM receiver.
  2. Connect the D-Type 9-way plug (sockets) marked DATA to your PC or other data monitoring device.
  3. Switch on and tune the receiver to a transmission carrying data.
  4. Your data will be received across the link.
-

## 4.6 Connecting Control Signals

The AXRX-QDM receiver's internal settings for the receiver and the Field Controller can be controlled by external software when connected to a PC. This connection could be through the IP network or a USB serial connection.

The Mission Controller software package is available to support external control of the AXRX-QDM receiver and the Field Controller, and give a full deployment management tool.

### Before you Start

This is necessary:

- AXRX-QDM receiver
- Ethernet Cable Assembly (optional)
- A PC with a web browser.

### Step 1: Connect Data Signal

1. Connect the RJ45 8-way plug to the ETHERNET receptacle of the AXRX-QDM receiver.
2. Connect the other RJ45 plug to the Ethernet receptacle on your PC.

## 4.7 About IP Control

The AXRX-QDM uses IP Control to share data with a Personal Computer for most programming operations. This is the primary means of connecting to the device and gives access to settings and configurations quickly and easily.

The IP interface enables you to control the unit with a PC with a web browser and for streaming video. The RJ45 connector on the rear of the unit marked **Ethernet** is compatible with 10/100 Base-T Ethernet networks.

The unit passes IP signals through the **IP interface** on the bottom panel. This is an RJ45 Jack.

## 4.8 About Mission Commander

Mission Commander is a software tool designed to configure and manage Wave Central devices.

The AXRX-QDM Field Controller can be configured and upgraded by connecting to Mission Commander through the USB port on the side panel.

---



## 5. Basic Operation

### 5.1 Starting and Stopping the AXRX-QDM Receiver

AXRX-QDM receiver units don't have power switches – you simply apply power to them and they will start up.

#### Before you Start

This is necessary:

- A AXRX-QDM receiver
- A source of power.

#### Step 1: Powering Up

1. Power-on the AXRX-QDM receiver with one of the procedures in Setting up your AXRX-QDM Receiver earlier.
2. You'll see an image on the Field Controller screen on the front panel.

#### Step 2: Stopping the System

It is important to stop the system carefully. This makes sure that all processes are terminated correctly and no data or settings become unavailable.

1. Make sure the unit is not updating software or applying configuration changes, and that the unit is not in sleep mode.
2. Disconnect the power cable from the AXRX-QDM receiver.
3. On the front panel the Field Controller screen will go off. (Screen will stay on if connected to PC with USB)
4. The system is stopped safely.

#### Next Steps

Exploring the Control Panel.

### 5.2 Working with the Control Panel

The control panel is presented as a **Field Controller** and is on the front panel.

#### Before you Start

This is necessary:

- A fully powered AXRX-QDM receiver.
-

## Step 1: Interpret the Display

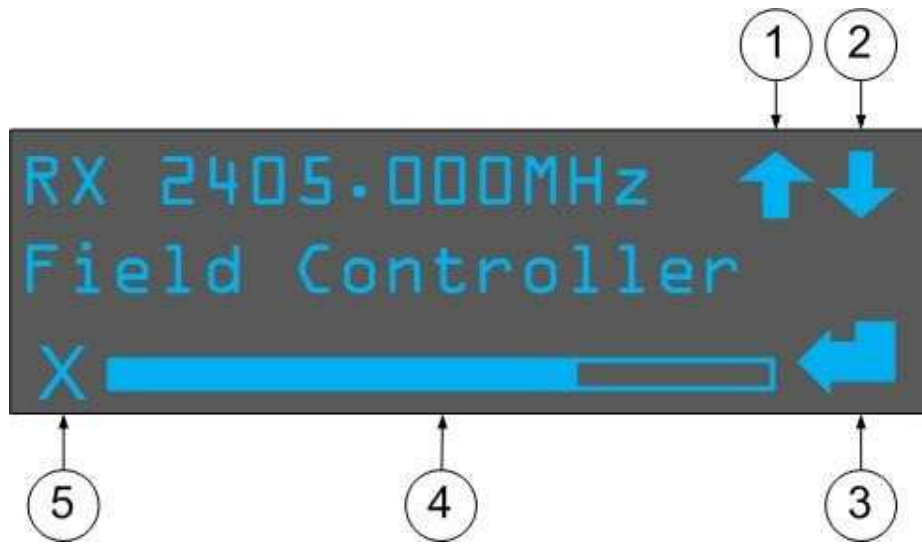

**Figure 5-1 Working with the Control Panel**

No	Name	Notes
1	Up Arrow	There are more options available in this menu. Push the navigation button <b>Up</b> to see more options.
2	Down Arrow	There are more options available in this menu. Push the navigation button <b>Down</b> to see more options.
3	Enter Arrow	There are sub-level menus available <b>OR</b> it is necessary to make sure of a step, such as changing a setting. Push the navigation button to <b>access the sub-level menu</b> or <b>save the changes</b> you have made to that setting.
4	Scroll Left and Right	It is possible to scroll left and right. Push the navigate button <b>right to scroll right</b> or <b>left to scroll left</b> . This is usually for entering textual or numeric information.
5	Exit Symbol	It is possible to Exit the current part of the menu. Push the cancel button to <b>go up one level</b> . Changes made will not be saved.

**Table 5-2 – Working with the Control Panel Key**

## Step 2: Use the Field Controller Screen Lock

To lock the Field Controller, simply hold down the two buttons on the front panel for approximately four seconds. A small key symbol will show in the bottom right corner of the screen. To unlock the screen simply hold down the buttons again for four seconds.

## 5.3 Exploring the Control Panel Menu Structure

The Field Controller has three primary menus each of which have many sub-menus. By navigating through these menus, it is possible to see the status of the unit's parameters and change settings without the use of a PC. The three menus are:

- Unit Status
- Unit Control
- Local Settings.

### Before you Start

This is necessary:

- A fully powered AXRX-QDM receiver.

### Step 1: Explore the Unit Status Menu Structure

Top Menu	Second Level	Function	Default Value
<b>Unit Status</b>	<b>Freq</b>	Shows current receiver frequency	2405.000MHz
	<b>SNR A</b>	Shows current SNR (Antenna A)	N/A
	<b>SNR B</b>	Shows Current SNR (Antenna B)	N/A
	<b>B/W</b>	Shows current bandwidth	N/A
	<b>Pre Err</b>	Shows the bit error rate for pre-errors.	N/A
	<b>Post Err</b>	Shows the bit error rate for post-errors.	N/A
	<b>Pkt Err</b>	Shows the number of packet errors coming out of the error correction system.	N/A
	<b>Input level A</b>	Shows the level in dBm of the signal being received on antenna A	N/A
	<b>Input level B</b>	Shows the level in dBm of the signal being received on antenna B	N/A

---

	<b>IP Addr</b>	Shows current IP address of the unit	172.16.1.120
	<b>FPGA Temp</b>	Shows FPGA Temp (°c)	N/A
	<b>S/W Ver.</b>	Shows current software issue number of the receiver device (D350 PCB)	N/A
	<b>ESN</b>	Shows electronic serial number	N/A

**Table 5-2 – Working with the Unit Status Menu**

## Step 2: Explore the Unit Control Menu Structure

Top Menu	Second Level	Third Level	Function	Default Value
<b>Unit Control</b>	<b>RF</b>	<b>Freq</b>	Set Unit Frequency	2405.000MHz
		<b>Demod</b>	Set narrowband or DVB-T	NB
	<b>NB Demod</b>	<b>B/W</b>	Set Narrowband bandwidth (2.5MHz, 1.25MHz, 625kHz)	2.5MHz
		<b>Guard</b>	Set Guard Rate (1/16, 1/8)	1/16
		<b>Spectrum</b>	Set spectrum type (Auto, Normal or inverted)	Norm
	<b>DVB-T Demod</b>	<b>B/W</b>	Set DVB-T bandwidth (8MHz, 7MHz, 6MHz)	8MHz
		<b>Decoder</b>	Set decoder delay (Low delay or Compliant)	Low Delay
		<b>Guard</b>	Set Guard Rate (Auto, 1/4, 1/8, 1/16, 1/32)	Auto
		<b>Spectrum</b>	Set spectrum type (Auto, Normal or inverted)	Auto
	<b>Decoder</b>	<b>Service</b>	Set unit Identifier	Solo-1
	<b>IP</b>	<b>DHCP</b>	Set DHCP (On or Off)	On
		<b>IP Addr</b>	Set IP address	172.16.1.120
<b>Netmask</b>		Set IP Net Mask	255.255.255.0	

Top Menu	Second Level	Third Level	Function	Default Value
		<b>Gateway</b>	Set IP Gateway	0.0.0.0
		<b>UDP Stream</b>	Set UDP ( On or Off)	Off

**Table 5-3 – Working with the Unit Control Menu**

### Step 3: Explore the Local Settings Menu Structure

Top Menu	Second Level	Function	Default Value
<b>Local Settings</b>	<b>Serial</b>	Shows unit serial number	N/A
	<b>S/W Ver.</b>	Shows loaded software version of FCON controller	N/A
	<b>Name</b>	Set unit name	Field Controller
	<b>Menu Level</b>	Set FCON menu availability (Full, Basic or User)	Full

---

Top Menu	Second Level	Function	Default Value
	<b>AXRX-QDM FP</b>	Change the FCON display to AXRX-QDM mode (On or Off)	Off
	<b>RS232 Ctrl</b>	Set RS232 control function (On or Off)	On
	<b>Status Display</b>	Show frequency on FCON display (On or Off)	On
	<b>LEDs</b>	N/A	
	<b>Voltage Disp</b>	Shows voltage input on FCON screen (On or Off)	Off
	<b>Low Batt Disp</b>	Shows Low battery warning (On or Off)	Off
	<b>Low Batt</b>	Set voltage at which Low battery warning appears (0-16V)	7.000V
	<b>Brightness</b>	Sets FCON display brightness (a number between 0 and 255)	00128
	<b>Disp Mode</b>	Set FCON display power-save mode (On, Auto Dim, Auto Off)	Auto Dim
	<b>Boot Logo</b>	Show Cobham boot logo on start-up (On or Off)	On
	<b>Terminal Mode</b>	Set terminal mode (Yes or No)	No
	<b>Time</b>	Shows Time Stamp	Not Set
	<b>Date</b>	Shows Date Stamp	Not Set

**Table 5-4 – Working with the Local Settings Menu**

## 5.4 Working with the Display System

The Field Controller fitted to the AXRX-QDM Receiver can show all the primary parameters of the unit by scrolling through the menus as shown above. There is also a primary screen which can be set to continuously show some of the key parameters.

## Before you Start

This is necessary:

- A fully powered AXRX-QDM receiver.

### Step 1: Interpret the Display

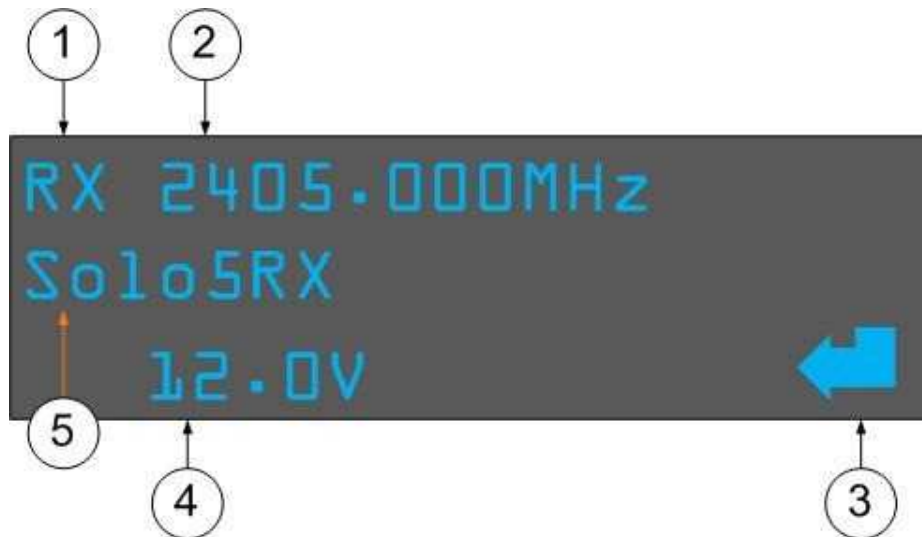

**Figure 5-5 Working with the Display System**

No	Notes
1	The unit is identified as a Receiver.
2	Receiver Frequency.
3	Enter Symbol
4	Voltage Indication.
5	Unit Identifier.

**Table 5-6 – Working with the Display System**

**Note:** Some of the features on this screen can be disabled for covert operations and the display can be set to shut off after 10 seconds to keep battery life. You can also set up the display to behave and look like the AXRX-QDM units from before.

## Step 2: Use the AXRX-QDM Front Panel Type Display

The Field Controller display can be set to emulate the earlier style AXRX-QDM display; if you know WaveCentral's AXRX-QDM range you will know this configuration.

The screen is designed to give the user a simple visual representation of the unit's status during operation.

1. From the primary Field Controller Screen, push the navigation button to go to the top level of the menu.
2. Use the navigation button to scroll down to **Local Settings** and push the navigation button to go into this menu.
3. Then scroll down to **AXRX-QDM front panel** and push the navigation button.
4. Push the navigation button up or down to toggle between the two options **On** or **Off**, select **On** and push the navigation button to save the changes.
5. Push the **Back** button continuously until you see the primary Field Controller display, you will find that the display has changed and looks like this:

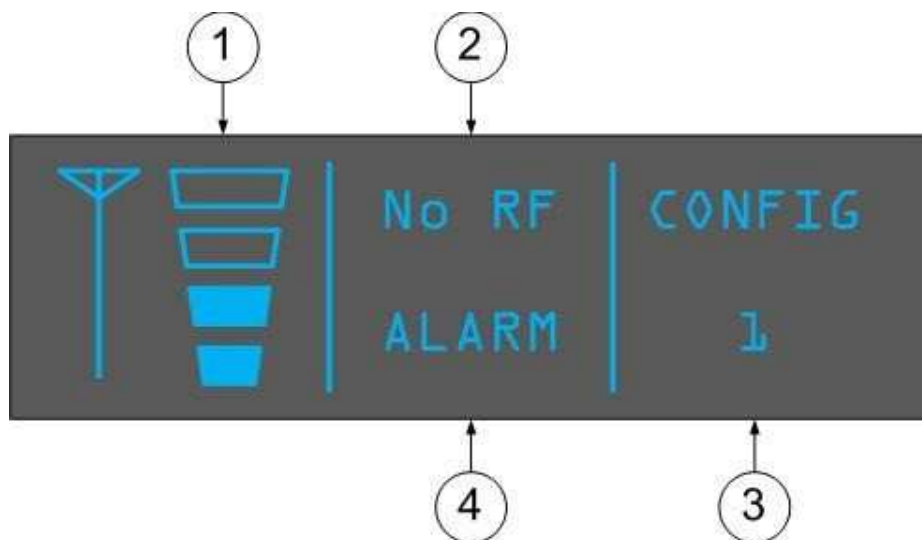

**Figure 5-7 AXRX-QDM Front Panel Type Display**

No	Name	Notes
1	Signal level indicator	Shows the strength of the incoming RF signal. This unit is showing half signal strength.
2	RF lock indicator	Shows <b>No RF</b> when there is no lock. Shows <b>RF OK</b> when the unit is locked.
3	Current configuration	Shows the current configuration of the unit, this could be any of the 16 programmable presets.



4	Alarm Indicator	Shows only when there is an alarm or fault on the unit. This usually means that there is no RF lock or the incoming stream cannot be decrypted.
---	-----------------	---

**Table 5-8 – AXRX-QDM Front Panel Display Key**

## 7.1 Installing the Web Browser on your PC

**Note:** Most PCs will have a browser installed. This topic is only necessary if you wish to change to a different browser.

### Before you Start

This is necessary:

- A PC with Windows XP or better.
- The PC to have a network card configured for a fixed IP Address.
- The Browser Application you wish to use. (Internet Explorer or Firefox for example).

### Step 1: Install the Browser Application on your PC

1. Install Browser on your desktop or other convenient location on your PC.
2. Make sure you have a Browser start-up icon on your desktop to start the program.

### Next Steps

Connect your PC to the AXRX-QDM Receiver with IP.

## 7.2 Connecting your PC to the AXRX-QDM Receiver with IP

You'll wish to configure your AXRX-QDM Receiver to do useful operations immediately.

The AXRX-QDM Receiver has **Control Pages** accessed from your web browser which enables you to do many configuration tasks quickly and easily.

### Before you Start

This is necessary:

- A PC with a web browser.
- An Ethernet cable.
- A powered AXRX-QDM Receiver unit.
- The IP Address of the AXRX-QDM Receiver unit.

### Step 1 - Install the Web Browser Application on your PC

Make sure you have installed a **browser** (Internet Explorer, Firefox or Chrome for example) onto your Personal Computer (PC).

---

## Step 2: Make an IP Connection between AXRX-QDM Receiver and the PC

1. Connect the RJ45 8-way plug (pins) on the Ethernet Cable to the RJ45 8-way receptacle (sockets) on the AXRX-QDM receiver.
2. Connect the RJ45 8-way plug (pins) on the Ethernet Cable to the RJ45 8-way receptacle (sockets) of your Personal Computer.
3. Straight Ethernet cable NO cross-over cable.

## Step 3 - Open your Web Browser and Log on

1. On your PC, double-click your **Internet Browser** icon.
2. The Web browser **Home Page** window **opens**.
3. In the **Address bar**, type the **IP Address** of the AXRX-QDM Receiver you wish to configure like this example: `http://192.168.1.10/`
4. The **Windows Security** dialog box **opens**.
5. **Type** in your **Username**. (Default is **user**).
6. **Type** in your **Password**. (Default is **nanoweb**).
7. Click the **OK** button.
8. Your AXRX-QDM Receiver **Control Page** opens in your Web Browser.

**Note:** Sometimes you do not have to give a Username and password depending on the settings on the Global Settings page. Password checking can be turned off.

---

## Screenshot: Open Web Browser and Log on

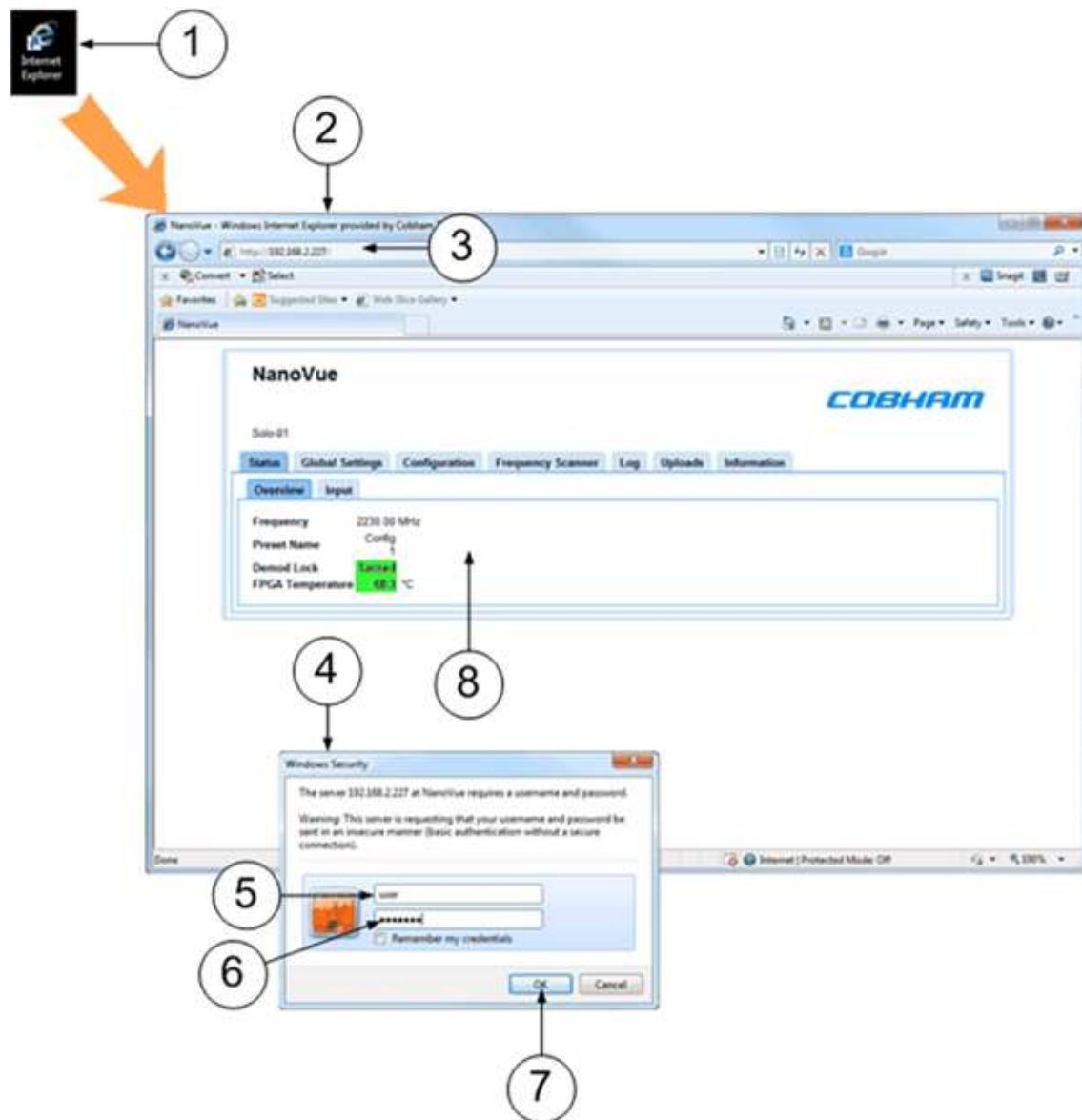

**Figure 7-1 Open Web Browser and Log on**

## Next Steps

Explore the Primary Window.

## 7.3 Exploring the Primary Window

### Before you Start

This is necessary :

- To have connected your PC to the AXRX-QDM Receiver with IP.
- To be logged on to the AXRX-QDM Receiver unit.

### Screenshot: Explore the Control Pages

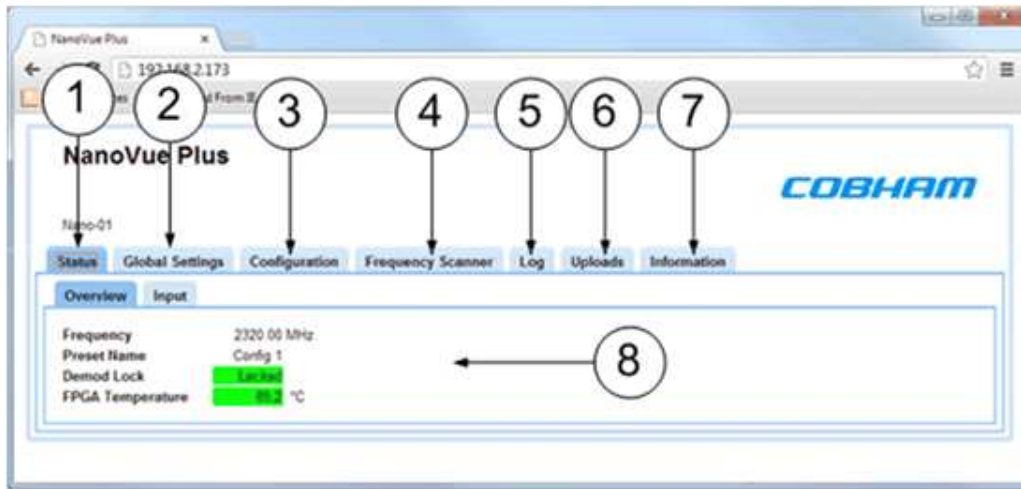

**Figure 7-2 Explore the Control Pages**

No	Name	Notes
1	Status tab	Divided into Overview and Input sub-tabs. This shows detailed status information of received signal quality and decoded video and audio services.
2	Global Settings tab	Divided into General Settings, IP Settings, OSD Settings, Audio Settings, External Downconverters and Streaming Settings panes.
3	Configuration tab	Divided into Demod, Decoder and Encryption panes. The Configuration tab contains the list of 16 presets. Each preset the user can specify demodulation parameters, decoding modes, and descrambling configuration.
4	Frequency Scanner tab	The AXRX-QDM Receiver can scan frequencies and find operating channels for you for tuning quickly.
5	Log tab	The AXRX-QDM Receiver can make log files of receiver status information.

No	Name	Notes
6	Uploads tab	Enables you to upload a license file, enable licensable features, or send software upgrade files to the AXRX-QDM Receiver.
7	Information tab	Contains information like software versions and unit data. This information will be necessary during a support call.
8	Overview sub-tab	Some tabs are divided into Sub-tabs which contain the fields you can operate with. This is one of two sub-tabs on the Status tab.  Other tabs are simply divided into panes of information fields.

**Table 7-3 – Control Pages Key**

## 7.4 Working with the Status Tab

The **Status Tab** shows detailed status information of received signal quality and decoded video and audio services.

The Status Tab is divided into two sub-tabs:

- Overview
- Input

### Before you Start

This is necessary:

- To have connected your PC to the AXRX-QDM Receiver with IP.
- To be logged on to the AXRX-QDM Receiver unit.

### Step 1: Open the Overview Sub-Tab

1. Click on **Status > Overview** tab.

## Screenshot: Overview Sub-Tab

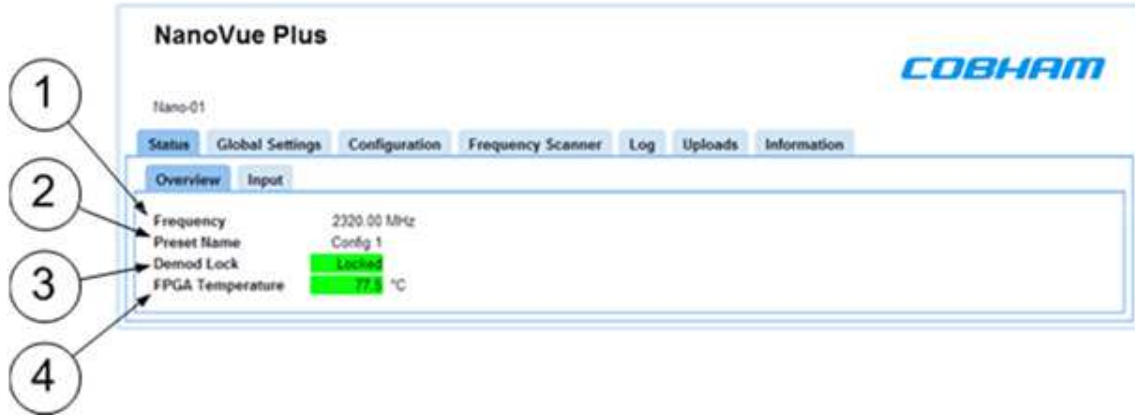

**Figure 7-4 Status Tab showing Overview Sub-Tab**

## Step 2: Interpret the Overview Sub-Tab

No	Name	Options	Notes
1	Input frequency (MHz)	S and C Bands	Reports the <b>frequency</b> in megahertz (MHz) to which the receiver is tuned.
2	Preset Name	Config1, 2, 3, 4, 5, 6, 7, 8, 9, 10, 11, 12, 13, 14, 15, 16	This is the configuration you are currently working on. Only 1 to 16.
3	Demod Lock Status	Locked or Not Locked	Tells you if the unit has successfully demodulated the incoming RF signal.
4	FPGA Temperature	Any temperature	This field reports the current temperature of the FPGA in degrees Celsius. If the field background is green, the temperature is in limits. If the background shows red, then the FPGA is becoming too hot and the unit must be switched off immediately. It usually must be in the range of 50 to 80 degrees Celsius.

**Table 7-5 – Overview Sub-Tab Key**

### Step 3: Open the Input Sub-Tab

1. Click on the **Status > Input** tab.

#### Screenshot: Input Sub-Tab

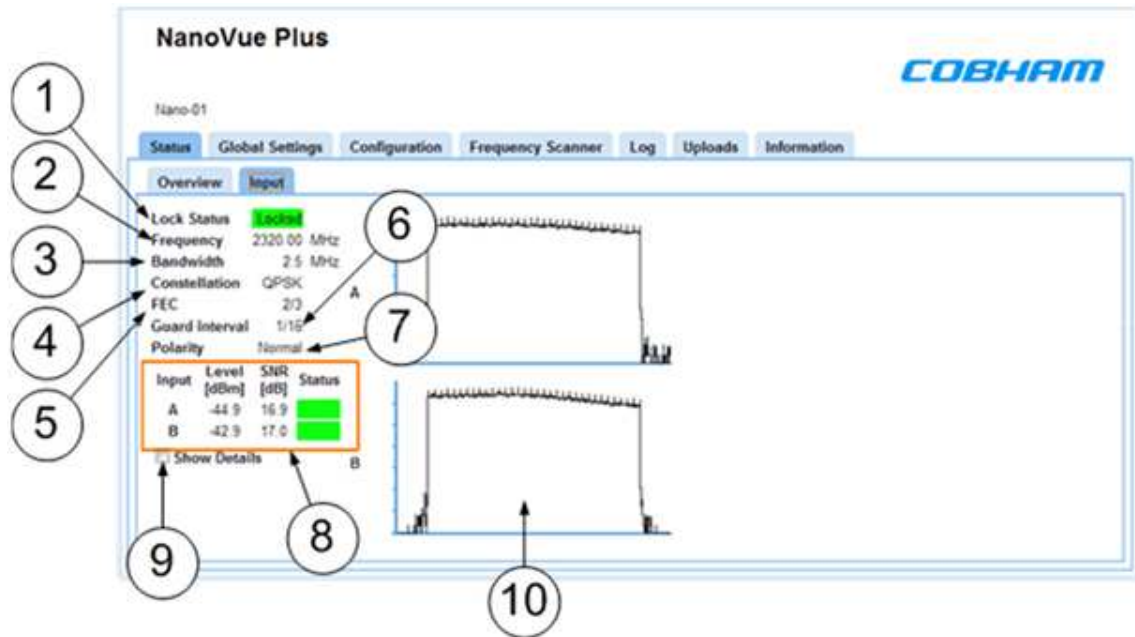

Figure 7-6 Status Tab showing Input Sub-Tab

### Step 4: Interpret the Input Sub-Tab

No	Name	Options	Notes
1	Decoder Lock Status	Locked (stable green background) or Not Locked (stable red background).	Tells you if the unit has successfully locked to the incoming bit stream.
2	Input frequency (MHz)	S and C Bands	The frequency in megahertz (MHz) to which the receiver is tuned.
3	Bandwidth	DVBT:6, 7 & 8MHz	DVB-T bandwidths (usually used for broadcast)

No	Name	Options	Notes
4	Constellation	QPSK, 16QAM, 64QAM	<p>This field indicates the OFDM constellation being received.</p> <p>QPSK-less user data, more robust, more range.</p> <p>16QAM-more user data, less robust, less range.</p> <p>The mode is automatically found and is simply shown here. You can't change it other than at the transmitter.</p>
5	FEC	1/2, 2/3, 3/4, 5/6 & 7/8	<p>This field indicates the forward error correction (FEC) rate which is being applied.</p> <p>Think 'data bits/all bits'</p> <p>1/3 means 1 bit out of 3 bits is data and thus 2 bits are used for error correction.</p> <p>A small quantity of user data means less picture quality, but more error correction means a more robust signal and thus more range.</p> <p>2/3 means 2 bits out of 3 bits are data and thus 1 bit is used for error correction.</p> <p>More user data means better picture quality, but less error correction means less robust signal and thus less range.</p> <p>The mode is automatically found and is simply shown here. You can't change it other than at the transmitter.</p>
6	Guard interval	DVBT: 1/32, 1/16, 1/8, 1/4	<p>The guard interval is a deliberate extension of the RF symbol period to give immunity to reflections.</p> <p>1/16, short extension, deals with fast reflections, more data, less range.</p> <p>1/8, long extension, deals with slower reflections, less data, more range.</p>



No	Name	Options	Notes
7	Polarity	Normal or Inverted	All WaveCentral equipment must use normal mode. The receivers can be used with other manufacturer's products and sometimes this requires us to change the polarity to inverted to align with this third party equipment.
8a	Input Level A		The level in dBm of the signal being received on antenna A There are readings for all antennas.
8b	Input A SNR	Could be any number.	The signal to noise ratio of the signal being received on antenna A. There are readings for all antennas.
8c	Status	Green or Red	A visual indication of signal strength.
9	Show Detail Check Box	Select or Clear	When selected, more details about the error corrector on this page are shown.
10	Spectrum Display	Displays for the A and B antenna are shown.	When tuned in you'll see the classic 'top hat' shape of a COFDM waveform.

**Table 7-7 – Input Sub-Tab Key**

### Step 5: Check the Show Details Checkbox

When checked, more details about the error corrector on this page are shown.

### Screenshot: Input Sub-Tab, Show Details Checked

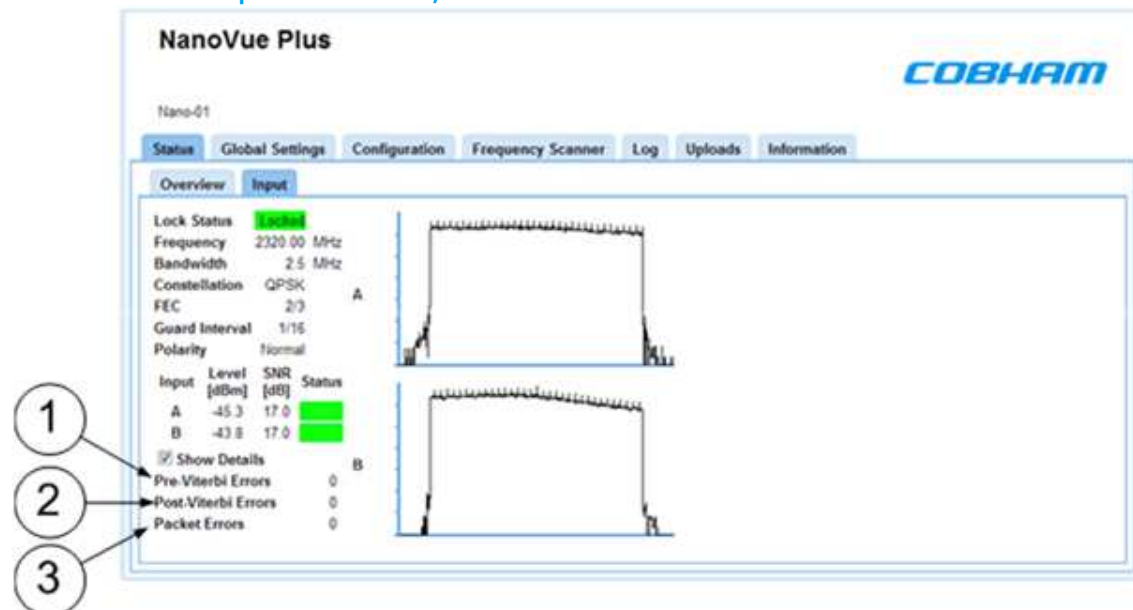

**Figure 7-8 Input Sub-Tab with Show Details Checked**

## Step 6: Configure the Details Fields

No	Name	Options	Notes
1	Pre-Viterbi Errors	0 is ideal.	The bit error rate for pre-errors.
2	Post-Viterbi Errors	0 is ideal.	The bit error rate for post-errors.
3	Packet Errors	0 is ideal.	The number of packet errors coming out of the error correction system. An error here will corrupt the video, audio or data signals coming through the receiver.

**Table 7-9 – Input Sub-Tab with Show Details Key**

## 7.5 Working with the Global Settings Tab

The Global Settings tab contains parameters that control global unit features common to all presets, including network parameters and OSD configuration.

The Global Settings tab is divided into six panes:

- General
- IP
- OSD
- Audio
- External Downconverters
- Streaming

### Before you Start

This is necessary:

- To have connected your PC to the AXRX-QDM Receiver with IP.
  - To be logged on to the AXRX-QDM Receiver unit.
-

## Step 1: Open the Global Settings Tab

1. Click on the **Global Settings** tab.

## Screenshot: Global Settings Tab

The screenshot shows the 'Global Settings' tab for the NanoVue Plus device. The interface is divided into several sections: General, OSD, Streaming, IP, Audio, and External Downconverters. The 'General' section includes fields for Unit Name (Nano-01), Touchscreen Password Enable (checkbox), Password (4030), Web Password (Set Password), Narrowband BW Hunt (checkbox), Screen Brightness (Day), and Video Out Format (PAL). The 'OSD' section includes Mode (Off), Spectrum (Channel A), and Time stamp (checkbox). The 'Streaming' section includes Streaming (Disabled), Streaming Source (Pre-Decryption), Multicast Address (224.2.128.12), Multicast TTL (127), Multicast Port (10333), Multicast Service Name (Video session), Stream Type (UDP Multicast), Stream Mode (Transport Stream), Recording (Stop), and SD Card (99% free). The 'IP' section includes DHCP Enable (checkbox), IP Address (192.168.2.120), Network Mask (255.255.255.0), and Gateway (0.0.0.0). The 'Audio' section includes Mute Feature Enable (checkbox), Mute (checkbox), and Headphone Volume (slider). The 'External Downconverters' section includes Presets (UHF (Internal)), LO Frequency (0 MHz), LO Side (Low), LNB Power (9V) (Off), and LNB Gain Offset (0 dB). At the bottom, there are buttons for 'Apply', 'Refresh', 'Set Clock...', and 'Format Filesystem...'.

Figure 7-10 Global Settings Tab

## Step 2: Configure the General Pane

## Screenshot: General Pane

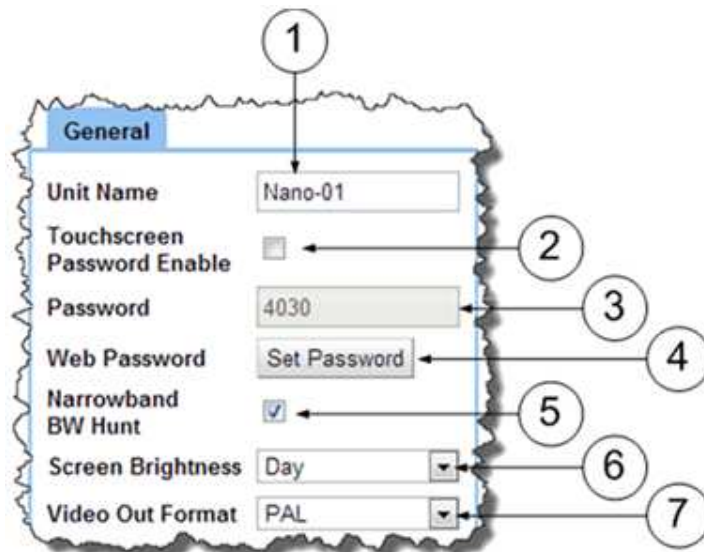

**Figure 7-1.1 Global Settings Tab, General Pane**

No	Name	Options	Notes
1	Unit Name	A combination of characters.	The name for the receiver. Used when the AXRX-QDM Receiver is streaming to identify the source.
2	Touchscreen Password Enable	Selected or Cleared.	When selected, you'll have to type a password to go into the setup pages of the touchscreen. When cleared it means no password is needed.
3	Password	Default is 4030. You can use four digits.	Only operates when Touchscreen Password Enable has been checked. <b>Note:</b> Does not apply to AXRX-QDM
4	Web Password Enable	Selected or Cleared.	When selected, you'll have to input a Username and Password to go into the Control Pages when using your web browser to configure the AXRX-QDM Receiver.

No	Name	Options	Notes
5	Narrowband BW Hunt	Selected or Cleared.	When Bandwidth Hunting is selected, and the unit is in Narrowband mode, AXRX-QDM Receiver will automatically change its bandwidth to align with that of the transmitter, if the unit is licensed for 1.25MHz and 2.5MHz. DVB-T bandwidths must be manually selected.
6	Screen Brightness	Day or Night	The Day setting is sufficiently bright to see in daylight. For night operations you can dim the screen by selecting Night mode. <b>Note:</b> Does not apply to AXRX-QDM
7	Video Out Format	PAL or NTSC	These are usually changed on the touchscreen, but for those OEM customers who are only working at board level; this switch does the same task.

**Table 7-12 – Global Settings Tab, General Pane Key**

## Step 3: Configure the IP Pane

### Screenshot: IP Pane

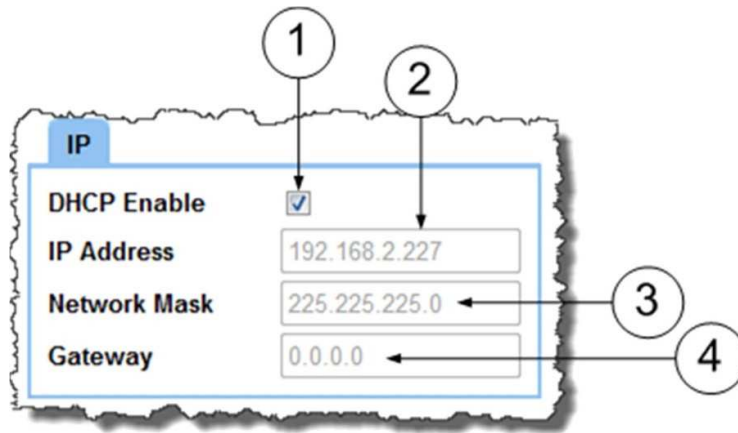

**Figure 7-13 Global Settings Tab, IP Pane**

No	Name	Options	Notes
1	DHCP Enable (Dynamic host configuration protocol)	Selected or Cleared.	When selected the AXRX-QDM Receiver is given an IP address by an external DHCP server.  In managed networks which use DHCP address allocation this must be selected. In networks that are manually managed (or do not have a DHCP server), users possibly prefer to give an IP address manually.
2	IP Address	Example: 192.168.2.120	If the AXRX-QDM Receiver is not automatically acquiring its IP address through a DHCP server then a fixed IP address needs to be given to the unit  Type in an <b>IP address</b> for this AXRX-QDM Receiver in the IP address text box. It can be a class of network of your choosing.
3	Network Mask	Example: 255.255.255.0	The network mask allows a network administrator to divide a network into smaller more useful subnets to stop large numbers of IP packets being routed through the network. This is usually specified by the network administrator  Type a <b>subnet mask</b> in the Network mask text box.

4	Gateway	Example: 192.168.2.120	<p>A default gateway is used by a host when an IP packet's destination address belongs to someplace external to the local subnet. The default gateway address is usually an interface belonging to the LAN's border router.</p> <p>We recommend you keep the gateway at the same setting as the IP Address.</p>
---	---------	---------------------------	---

**Table 7-14 – Global Settings Tab, IP Pane Key**

Step 4: Configure the OSD Pane

Screenshot: IP Pane

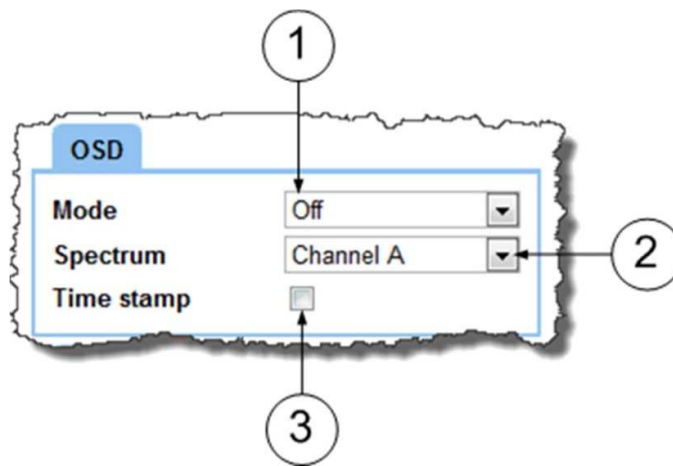

**Figure 7-15 Global Settings Tab, OSD Pane**

No	Name	Options	Notes
1	Mode	Off, Simple, Detailed, Engineering and Frequency Scan.	<p>You can select how much data is shown on the On-Screen Display (OSD). You can also switch the OSD off.</p> <p><b>Note:</b> the OSD <b>only</b> appears on the <b>external monitor</b> output of the AXRX-QDM Receiver.</p>
2	Spectrum	A or B	The OSD Spectrum display can be set to show antenna A or B.
3	Time Stamp	Selected or Cleared.	When selected, a timestamp is added to the OSD presentation.

**Table 7-16 – Global Settings Tab, OSD Pane Key**

## Step 5: Configure the Audio Pane

### Screenshot: Audio Pane

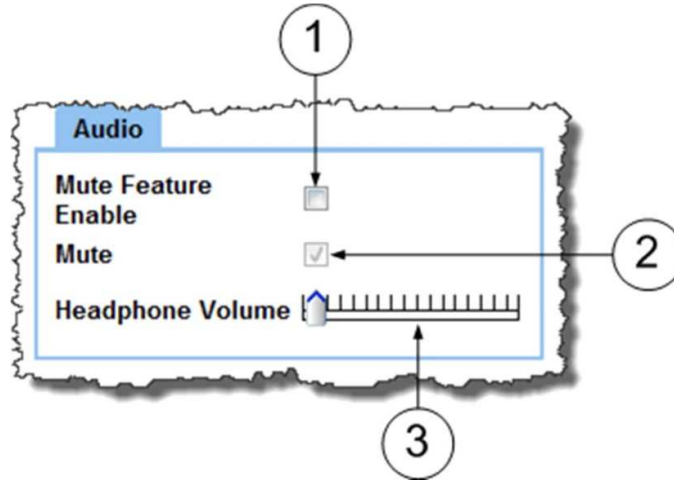

**Figure 7-17 Global Settings Tab, Audio Pane**

No	Name	Options	Notes
1	Mute Feature Enable	Selected or Cleared.	When selected, the mute item is shown on the touchscreen enabling you to mute or unmute the audio by a simple touch of the shown item. <b>Note:</b> Does not apply to AXRX-QDM
2	Mute	Selected or Cleared.	When selected, all audio is muted on the AXRX-QDM Receiver.
3	Horizontal Slider	Click and drag left or right	Drag left to lower the headphone volume. Drag right to increase headphone volume.

**Table 7-18 – Gbbal Settings Tab, Audio Pane Key**

## Step 6: Configure the External Downconverter Pane

**Note: The External Downconverter is a factory setting for the unit.**

## 7.6 Setting the Clock

### Before you Start

This is necessary:

- To have connected your PC to the AXRX-QDM Receiver with IP.
- To be logged on to the AXRX-QDM Receiver unit.

### Step 1: Open the Global Settings Tab

1. Click on the **Global Settings** tab.

### Step 2: Set the Clock

1. Click the **Set Clock** button
2. The **Set Clock** dialog opens
3. Set the **parameters** to how you wish the clock to be shown.
4. Click the **Set** button

### Screenshot: Set the Clock

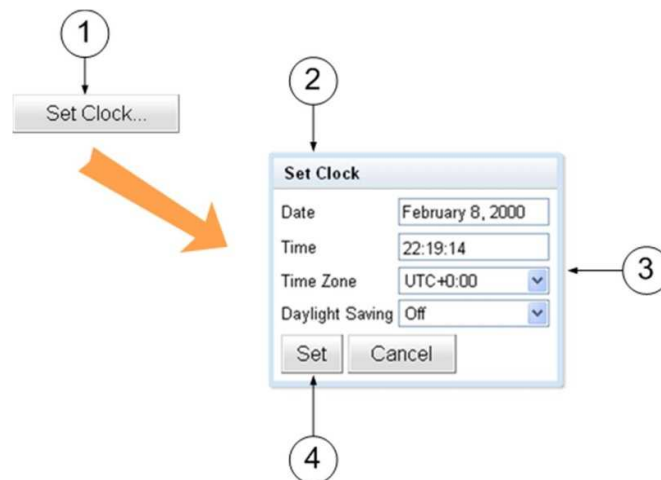

**Figure 7-19 Set the Clock**

## 7.7 Working with the Configuration Tab

The **Configuration** tab contains the list of 16 presets. Each preset the user can specify demodulation parameters, decoding modes, and descrambling configuration.

You can easily load a different preset by selecting one of the 16 configuration tabs and clicking **Apply**.

The **live** preset is indicated by a **green box** around the preset number.

Changes to the live preset are automatically applied with the **Apply** button. Changes made to all other non-live presets can be saved by clicking on **Save**.

---



The Configuration tab is divided into three panes:

- Demod
- Decoder
- Encryption

## Before you Start

This is necessary :

- To have connected your PC to the AXRX-QDM Receiver with an IP connection.
- To be logged on to the AXRX-QDM Receiver unit.

## Step 1: Open the Configuration Tab

1. Click on the **Configuration** tab.

## Screenshot: Configuration Tab

The screenshot shows the NanoVue Plus web interface. At the top, the title "NanoVue Plus" and the "COBHAM" logo are visible. Below the title, the device name "Nano-01" is displayed. A navigation bar contains tabs for "Status", "Global Settings", "Configuration", "Frequency Scanner", "Log", "Uploads", and "Information". The "Configuration" tab is selected and highlighted. Below the navigation bar, a row of numbered tabs (1-16) is shown, with tab 1 being active. The main configuration area is divided into three panes: "Demod", "Decoder", and "Encryption".

**Demod** settings:

- Preset Name: Config 1
- Frequency: 2320 MHz
- Bandwidth: 2.5MHz
- Guard Interval: 1/16
- Polarity: Normal
- Mode:  Narrowband  DVBT

**Decoder** settings:

- Decoder Input: Antennas
- PCR Mode: Recovered
- MPEG-2 Decoder: Low Delay
- Service Name: Solo-01
- Program Number: 1

**Encryption** settings:

- Decryption Mode: Off
- Decryption Keys: Change Keys

Buttons at the bottom include "Save", "Apply", and "Restore Defaults".

**Figure 7-20 Configuration Tab**

## Step 2: Understand the Preset Tab Colors

1. The **green box** shows which preset is currently **in operation** in the receiver.
2. The **light blue** tab shows presets available for you to use (There are 16).
3. The **dark blue** tab shows the preset you are currently **editing**.

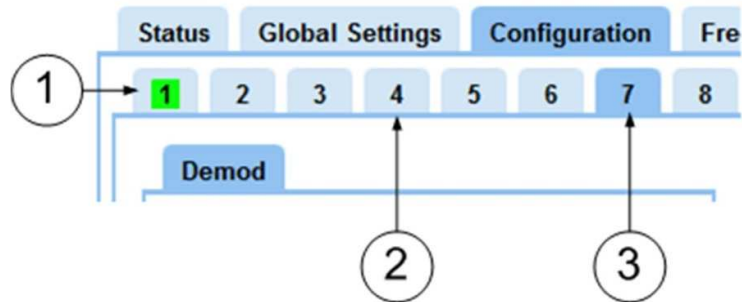

**Figure 7-21 Preset Tab Colors**

## Step 3: Make a Different Preset Available for Editing

1. Click on a **light blue** tab.
2. The tab turns **dark blue** and you are **editing** that preset at this time.

## Step 4: Make a Different Preset in Operation on the Receiver

1. Click on a **tab** other than the green one.
2. Click the **Apply** button.
3. The tab turns **green** and that preset is **in operation** on the receiver at this time.

## Step 5: Configure the Demod Pane

### Screenshot: Demod Pane

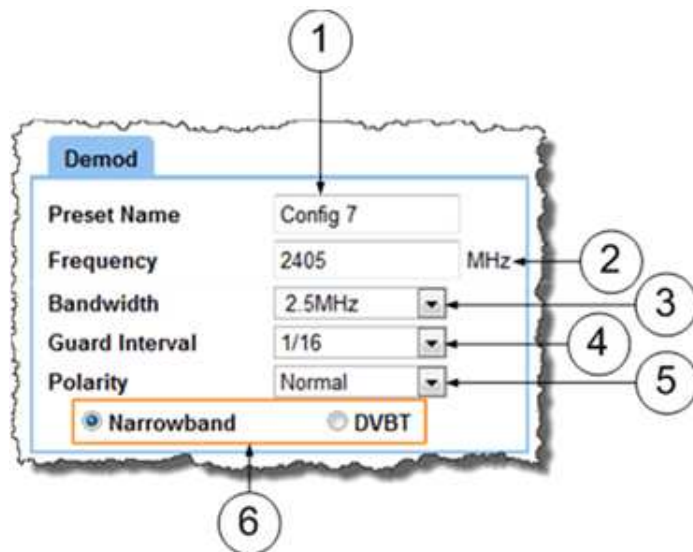

**Figure 7-22 Configuration Tab, Demod Pane**

No	Name	Options	Notes
1	Preset Name	Config 1, 2, 3, 4, 5, 6, 7, 8, 9, 10, 11, 12, 13, 14, 15, 16 or a text value.	This is where you <b>set</b> the current configuration.
2	Frequency (MHz)	S and C Bands	The frequency in megahertz (MHz) that you wish to use for this preset.  If you try to input a frequency that is out of range, the radio will tune the nearest available frequency automatically.
3	Bandwidth	DVBT: 6, 7 & 8 MHz Narrowband: 2.5 MHz 1.25 MHz 625 kHz	DVB-T bandwidths (usually used for broadcast)  WaveCentral narrowband (usually surveillance use)  WaveCentral Ultra-narrowband (this is a licensable item, usually surveillance use).
4	Guard interval	DVBT: 1/32, 1/16, 1/8, 1/4	The guard interval is a deliberate extension of the RF symbol period to give immunity to reflections.  1/16, short extension, deals with fast reflections, more data, less range.  1/8, long extension, deals with slower reflections, less data, more range.
5	Polarity	Normal or Inverted	All WaveCentral equipment must use normal mode. The receivers can be used with other manufacturer's products and sometimes this requires us to change the polarity to inverted to align with this third party equipment.
6	Bandwidth Mode Option Buttons	Narrowband or DVBT	This pair of option buttons lets you to select between Narrowband and DVBT modes. If you select narrowband then the narrowband radio settings apply. If you select DVBT then the DVBT radio settings come alive.

**Table 7-23 – Configuration Tab, Demod Pane Key**

## Step 5: Configure the Decoder Pane

### Screenshot: Decoder Pane

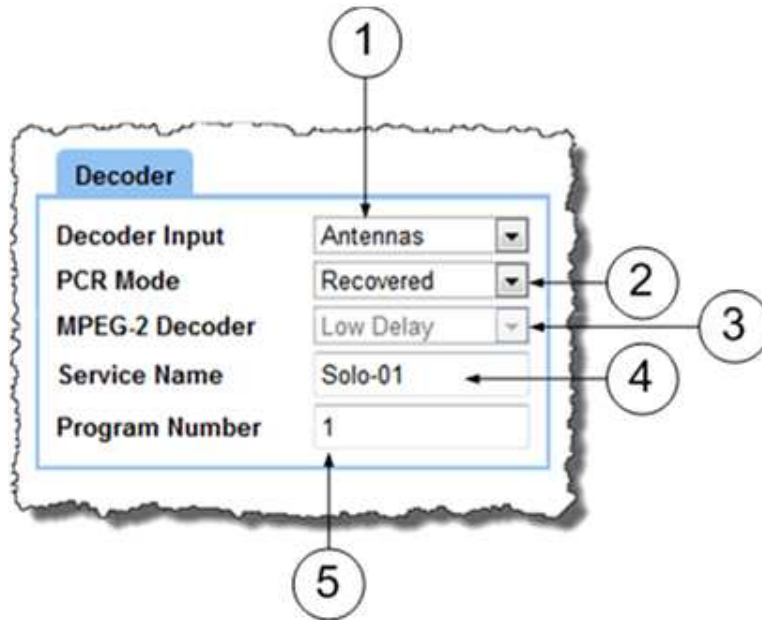

**Figure 7-24 Configuration Tab, Decoder Pane**

No	Name	Options	Notes
1	Decoder Input	Antennas Chaining	The decoder can operate with one of two sources: Antennas- the received radio signal. Chaining – Not Used
2	PCR Mode	Recovered Free-Running	This is the Program Clock Reference (PCR) mode. Usually synchronization is <b>recovered</b> from time stamps generated at the transmitter.  If this is not possible then the unit can be put in Free-Running where time stamps are generated locally in the receiver. This can be a problem for synchronization to some degree.
3	MPEG-2 Decoder	Low Delay or Fully Compliant	These modes only apply to DVB-T modes.

No	Name	Options	Notes
4	Service Name	Solo-01 is default but it could be anything.	This text box lets you name the multicast stream as delivered in the SAP/SDP packets from the unit. Default is <b>Solo-01</b> .  The Service Name on the receiver must align with the transmitter's service name.
5	Program Number	1	First program in the stream.

**Table 7-25 – Configuration Tab, Decoder Pane Key**

## Step 6: Configure the Encryption Pane – NOT USED

## 7.8 Working with the Frequency Scanner Tab

The **Frequency Scanner** tab enables you to scan the spectrum around you in a **bandwidth** and **resolution** of your choice.

You can use the **Find** function which will tag the strongest signals and report their frequencies to you.

You can use the **Cycle** button to select found frequencies in turn and if you wish you can push the **Select** button which will make that frequency currently in operation in your AXRX-QDM Receiver.

### Before you Start

This is necessary:

- To have connected your PC to the AXRX-QDM Receiver with an IP connection.
- To be logged on to the AXRX-QDM Receiver unit.

### Step 1: Open the Frequency Scanner Tab

1. Click on the Frequency Scanner tab.

### Screenshot: Frequency Scanner Tab

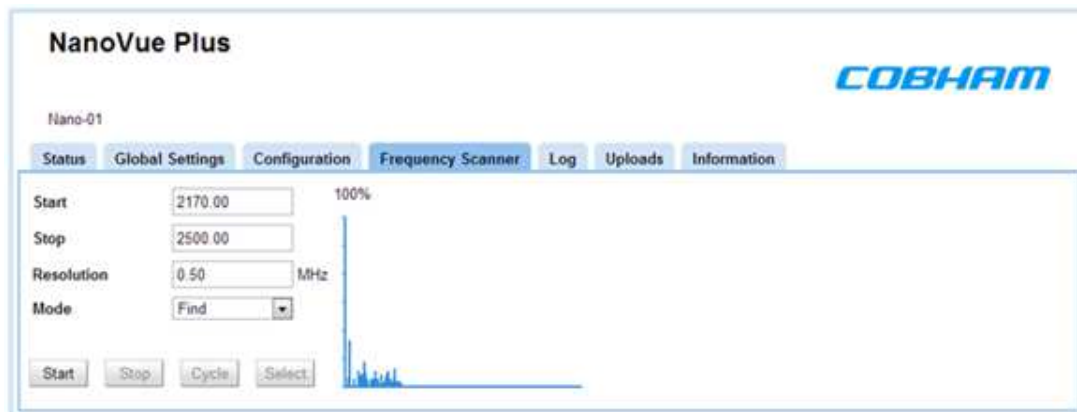

**Figure 7-25 Frequency Scanner Tab**

## Step 2: Set the Start

Type in the **Start** frequency in MHz you wish to use for your Frequency scan. If you type a frequency that is too low the Start frequency will set itself to the lowest frequency this AXRX-QDM Receiver can do.

## Step 3: Set the Stop

Type in the **Stop** frequency in MHz you wish to use for your Frequency scan. If you type a frequency that is too high the Stop frequency will set itself to the highest frequency this AXRX-QDM Receiver can do.

**Note:** If you set a wider band to scan with the Start and Stop setting, a longer scan time will be necessary.

## Step 4: Set the Resolution

Type in the **Resolution** frequency in MHz you wish to use for your Frequency scan. If you type a very small resolution like 0.5 MHz the scan will find many more discrete frequencies but a longer scan will be necessary.

Using a larger resolution will speed up the scan but can miss very small frequency steps.

## Step 5: Set the Mode

You can select Find or Plot.

- **Plot** scans the bandwidth you specified and shows you the plot of the spectrum.
- **Find** does the same but marks the strongest received frequencies in green and reports their frequencies. At this time, you can cycle through and select one of these found frequencies to be the AXRX-QDM Receiver current frequency.

## Step 6: Start the Frequency Scanner in Plot Mode

1. Make sure the **Mode** has been set to **Plot**.
  2. Click the **Start** button.
  3. The **Start Scan** window opens.
  4. Click the **OK** button.
  5. Monitor the **progress counter** until it reaches 100%.
  6. Monitor the **graphical display** of the scan.
-

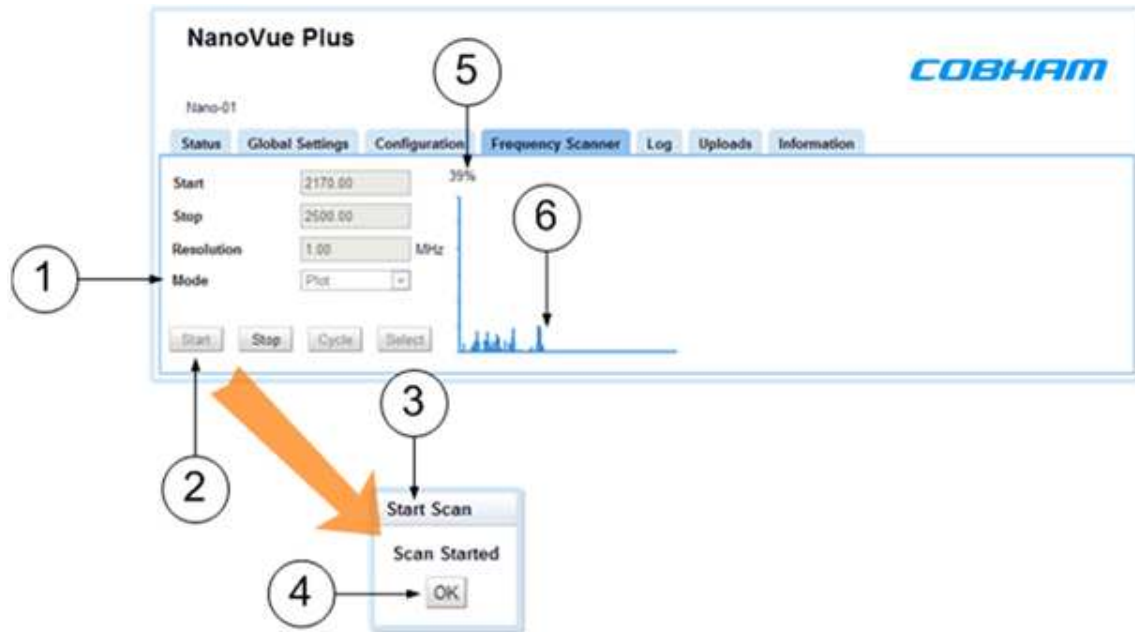

**Figure 7-27 Frequency Scanner in Plot Mode**

### Step 7: Start the Frequency Scanner in Find Mode

1. Make sure the **Mode** has been set to **Find**.
2. Click the **Start** button.
3. The **Start Scan** window opens.
4. Click the **OK** button.
5. Monitor the **progress counter** until it reaches 100%.
6. Monitor the **progress counter**– it will go through to 100% a **second** time.
7. Monitor the **graphical display** of the scan.
8. The green lines are **found frequencies**. The darker green line is currently selected.
9. Monitor the **Found Frequency Display**. It reports the frequencies in MHz of the found frequencies on the plot. The frequency with the green box is the currently selected frequency.

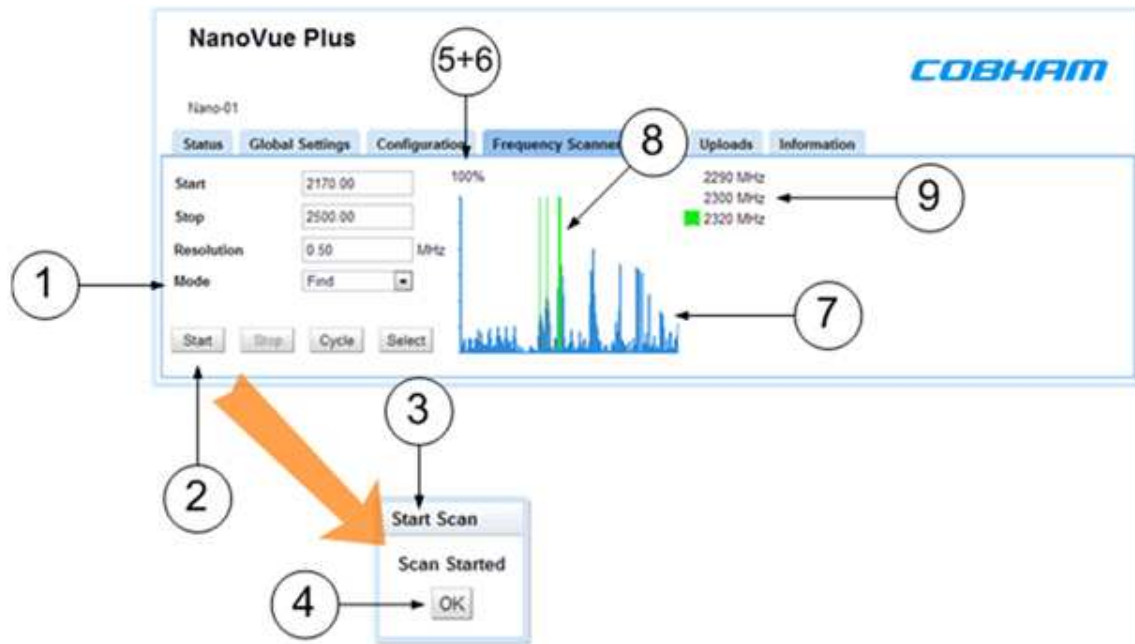
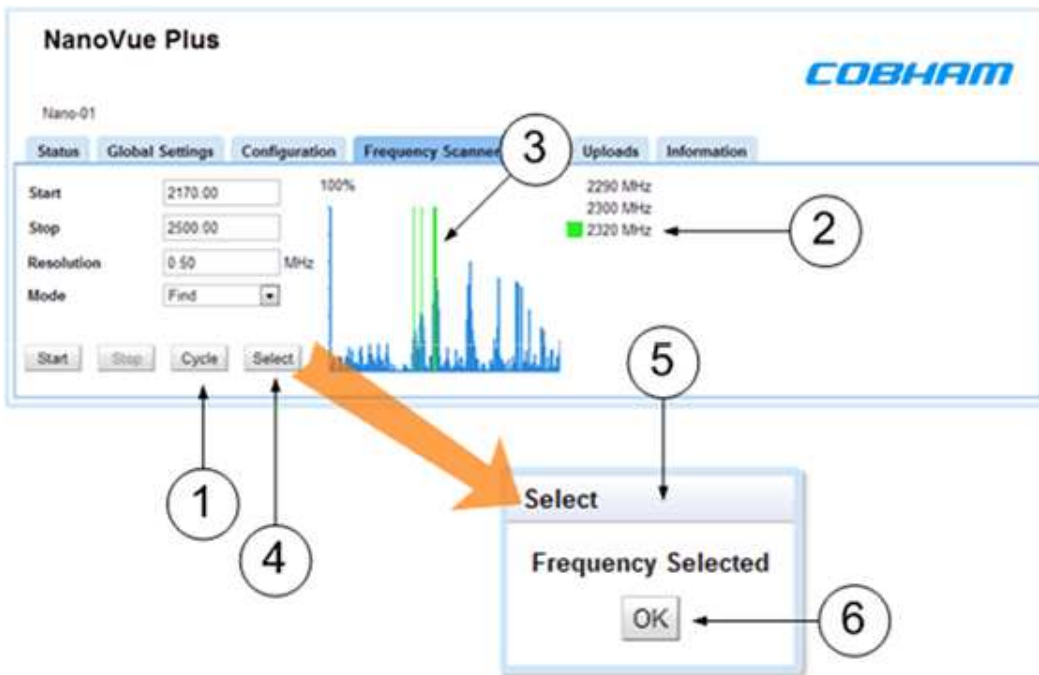

Figure 7-28 Frequency Scanner in Find Mode

### Step 8: Cycle though and Select Found Frequencies

1. After a Find frequency scan is finished, click the **Cycle** button
2. The **Found Frequency Display** will cycle through its frequencies. The **green box** will move on each click of the cycle button to show the current frequency.
3. As you click the cycle button the **darker green** line will show the current frequency. It tracks the green box in the Found Frequency Display.
4. When you have cycled to the frequency you wish to tune into the AXRX-QDM Receiver, click the **Select** button.
5. The **Frequency Selected** window opens.
6. Click the **OK** button. At this time, your AXRX-QDM Receiver is tuned to the frequency you selected.





**Figure 7-29 Cycle through and Select Found Frequencies**

## 7.9 Working with the Log Tab

**FACTORY USE ONLY**

## 7.10 Working with the Uploads Tab

**Factory Use Only**

## 7.11 Working with the Information Tab

The Information tab contains generic information like software versions and unit data. This information is necessary during a support call.

### Before you Start

This is necessary:

- To have connected your PC to the AXRX-QDM Receiver with an IP connection.
- To be logged on to the AXRX-QDM Receiver unit.

### Step 1: Open the Information Tab

1. Click on **Information** tab.

## Screenshot: Information Tab



**Figure 7-30 Information Tab**

### Step 2: Check the Software Version

This field shows the current version of software loaded onto the AXRX-QDM Receiver unit. When you do an upgrade, you must look here to make sure that the upgrade was correct.

### Step 3: Check the Serial Number

During a support call, it can be necessary for you to tell us the Serial Number of your AXRX-QDM Receiver.

### Step 4: Check the MAC Address

Media Access Control Address (MAC) is reported by this field. This can be necessary if you are involved in network operations with your AXRX-QDM Receiver.

### Step 5: Check the Licensed Features

In my example above, I am licensed for all these features of the AXRX-QDM Receiver.

1. DVBT DeModulation
2. MPEG2 Decoder
3. MPEG4 Decoder
4. H.264 Decoder

## 8. Appendix A – Cautions and Warnings

### 8.1 Cautions and Warnings

Serial	Area	Note
1	Enclosures	<p>Do not remove factory installed screws or fastenings. Damage to the units can be caused and void warranties.</p> <p>Only approved personnel must open the device. There are no operations that required the user to access the device internally. There are no user serviceable parts internally.</p>
2	Maintenance	<p>Other than cleaning, no scheduled maintenance is required to make sure of the correct operation of the unit.</p>
3	Environment	<p>The equipment must not be used in dangerous or atmospheres that can cause corrosion. Users are reminded of the necessity of complying with restrictions regarding the operation of radio devices in refuel depots, chemical plants and locations where explosives are kept and/or used.</p>
4	Power Supply	<p>Make sure that the power supply arrangements are sufficient to align with the requirements of each device. Obey all electrical safety precautions.</p>
5	Electro Static Discharge (ESD) Precautions	<p>ESD guidelines must be followed for this electrostatic sensitive device.</p>
6	Lightning Hit	<p>There is a risk of lightning hits to antennas. The equipment must not be assembled in an area during lightning. Antennas must be adequately protected from lightning hits.</p>
7	Working at Height	<p>You must be careful when locating the device at height, for example on a mast. Make sure the unit is correctly attached to stop it falling and injuring personnel.</p>
8	Risk of Eye Injury	<p>You must be careful to stop your eye touching the antennas.</p>
9	Cables	<p>Connecting cables must not be put where they can become damaged or where they can be dangerous by personnel tripping on them.</p>

---

Serial	Area	Note
10	Thermal Control System	Energized devices always become hot during operation. If you operate this device in a closed area you must make sure it has sufficient airflow to keep it at a low temperature.  Also, if worn near the body, you must be careful to give protection the operator from large temperatures.
11	RF Emission System	When operating this device please make sure a distance of 20cm is kept between your device and your body while the device is transmitting.
12	Aircraft Safety	Operating this equipment on board aircraft is not permitted. Operating radio transmitter equipment in an aircraft can be dangerous to navigation and other systems.

**Table 8-1 – Cautions and Warnings**

## 8.2 EMC / Safety and Radio Approvals

The equipment has been designed to meet and has been tested against these harmonized EMC and safety standards:

The tests were done to EN 301 489-1: (2008-04), EN61000-3-2:2006 and EN61000-3-3:2008.

# 9. Appendix B - Precautions and Maintenance

## 9.1 Caring for your Equipment

- Do not apply physical abuse to the unit, too much shock or vibration.
  - Do not let it fall.
  - Do not shake or throw the unit.
  - Do not carry the unit by the antenna.
  - Prevent exposure to too much moisture or liquids.
  - Do not submerge the unit unless it is designed to be submersible.
  - Do not let the unit touch corrosives, solvents, cleaners or mineral spirits.
  - Prevent exposure to too much cold or hot.
  - Prevent too long exposure to direct sunlight.
  - Do not put or keep units on surfaces that are not stable.
-

- Always turn the unit off before installing optional accessories.
- Only use accessories intended for the specified make and model of your unit, especially batteries, chargers and power adapters.

## 9.2 Charging

- Use approved batteries, chargers and adapters designed especially for your make and model unit.
- Do not try to charge a wet unit or battery pack.
- Do not charge the unit or battery pack near anything flammable.
- Let the battery pack become stable at room temperature (72 degrees F) before charging.
- Do not charge units and / or battery packs on surfaces that are wet or not stable.
- Do not keep units and / or batteries in chargers for too long.

## 9.3 Working with Lithium Batteries

- Charge only with the approved charging cable.
- Batteries are to be used only for the specified function. Incorrect operation will invalidate the warranty and can make the battery become dangerous.
- Charge in a clean, dry environment, ideally at 10 degrees Celsius. (0 to 45 degrees Celsius is permitted).
- Do not keep or operate in direct sunlight for extended periods. Battery can be damaged by becoming too hot, for example if put on the rear parcel shelf of a vehicle.
- Keep in a cool and dry environment. Being kept too hot can cause permanent loss of capacity.
- For short term (fewer than six months), keep in a fully charged condition.
- For extended periods (more than one year) charge before keeping and charge at intervals of six to nine months.
- Always fully charge the battery after a period of more than one month before operation.
- Do not keep the battery with the charge low as this can cause the battery to become unserviceable and invalidate the warranty.
- Do not short circuit.
- Do not put in water.
- Do not burn. Cells are likely to explode if put in a fire.
- Dispose of batteries in accordance with the regulations for the Country of operation. Batteries are usually thought of as 'isolated waste' and must not be in the usual waste stream. Send to the seller, or send to an approved re-cycling company.

## 9.4 Cleaning

---

- Turn off the unit and remove batteries (if applicable) before maintenance.
- Use a clean, soft, moist cloth to clean the unit. A microfiber cloth is recommended.
- Do not use alcohol or cleaning solutions to clean the unit.
- Do not put the unit in water to clean it.
- If the unit becomes wet, immediately dry it with a microfiber or other lint-free cloth.

## 9.5 Storage

- Turn off the unit and remove batteries before storage
- Keep units and battery packs in a cool, dry area at room temperature (72 degrees F).
- Do not keep units and / or batteries in chargers which are on.

## 9.6 Repairs

Do not try to repair the unit. The unit contains no user serviceable parts. Speak to the Wave Central Customer Technical Support approved repair technician.

## 9.7 Getting Technical Support

### Step 1: Speak to Wave Central LLC

Technical support enquiries must be sent to the Wave Central Services team.

[tom@wavecentralrf.com](mailto:tom@wavecentralrf.com)

Phone: 1-888-736-9283. Office hours: 0900-1700 Eastern Time not including holidays.

Email: [tom@wavecentralrf.com](mailto:tom@wavecentralrf.com) (no restricted content).

For technical support we plan to give a first response to you in less than one working day and a progress update at intervals of two weeks at least.

## 9.8 Operate with the Wave Central RMA Service

If you have a problem and all troubleshooting steps have not worked, you must speak to Wave Central for Return Material Authorization (RMA) Service.

### Step 1: Email Wave Central

To send something to Wave Central please Email: [tom@wavecentralrf.com](mailto:tom@wavecentralrf.com) . We will then send you an RMA request form to complete and send to us. We'll then send you an RMA number and shipping instructions.

### Step 2: Put the Unit into the Box

Use the initial shipping container and packing materials if possible.

If the initial packing materials are not available, put the equipment in soft material (e.g. U/PE foam) then put the wrapped equipment into a hard cardboard shipping box.

---

### Step 3: Prepare an Information Sheet

Include a sheet with these items of information:

- Name
- Address
- Unit Serial Number
- Date of Purchase or the initial invoice number
- Date of problem
- A detailed description of the problems you have encountered
- A record of the hardware / software configuration if applicable

**Note:** Please keep a copy of this sheet for your records.

### Step 5: Put the RMA Number on the Box

Clearly identify the outer surface of the shipping box with the RMA number. If an RMA number is not on the shipping box, receiving cannot identify it and it might be sent to you again.

### Step 6: Send the Box to Wave Central

Send the box with your usual shipping procedure.

---

# 10. Appendix C-Glossary

## 10.1 Glossary

0-9	Means...
16QAM	16-state Quadrature Amplitude Modulation.
64QAM	64-state Quadrature Amplitude Modulation.

A	Means...
AC	<b>Alternating Current.</b> Current that is continually changing in magnitude and at intervals in direction from a zero reference level.
A/V	Audio/Video.
AES	In cryptography, the <b>Advanced Encryption Standard (AES)</b> is an encryption standard adopted by the U.S. government. The standard comprises three block ciphers, AES-128, AES-192 and AES-256, adopted from a larger collection originally published as <b>Rijndael</b> . Each AES cipher has a 128-bit block, with keys of 128, 192 and 256 bits, respectively. <b>Rijndael</b> is a family of ciphers with different key and block sizes.
ASI	<b>Asynchronous Serial Interface.</b> A streaming data interface which often carries an MPEG Transport Stream.  An ASI signal can carry one or multiple SD, HD or audio programs that are already compressed, not like an uncompressed SD-SDI (270Mbps) or HD-SDI(1.45Gbs). An ASI signal can carry differing quantities of data but is always padded to operate at a fixed line rate of 270 Mb/s.
Amplification	Increasing the strength (current, voltage or power) of a signal.
Amplitude	The level of an audio or other signal in voltage or current. The magnitude of variation in a changing quantity from its zero value.
Amplitude Modulation	Modulation in which the carrier wave heterodyned above and below its usual value in accordance with the intelligence of the signal being transmitted. Also called AM.
Analog	<b>Analog transmission</b> is a transmission method of conveying voice, data, image, signal or video information with a continuous signal which varies in amplitude, phase, or some other property in proportion to that of a variable.

---



<b>A</b>	<b>Means...</b>
Antenna	An <b>antenna</b> (or <b>aerial</b> ) is a transducer designed to radiate or receive electromagnetic energy (generally RF).
Antenna Bandwidth	The frequency range over which a given antenna will accept signals.
Antenna Gain	The effectiveness of a directional antenna as compared to a standard non-directional antenna. It is usually expressed as the ratio in decibels of standard antenna input power to directional antenna input power that will make the same field strength in the wanted direction. For a receiving antenna, the ratio of signal power values produced at the receiver input terminals is used. The more directional an antenna is, the higher is its gain.
Attenuation	Power loss resulting from conductor resistance and dielectric loss in the insulating material used to isolate the conductors.

<b>B</b>	<b>Means...</b>
BNC	<b>Bayonet Neil-Concelman</b> – A very well-known <b>type</b> of RF connector used for terminating coaxial cable.
Bandwidth	The width of a band of frequencies used for a function.

<b>C</b>	<b>Means...</b>
COFDM	<b>Coded Orthogonal Frequency Division Multiplexing</b> is a frequency-division multiplexing (FDM) scheme utilized as a digital multi-carrier modulation method. A large number of closely-spaced orthogonal sub-carriers are used to carry data.

<b>D</b>	<b>Means...</b>
D/C	Downconverter. A device which changes microwave frequencies to UHF frequencies for operation in Wave Central receivers.
Digital	A <b>digital signal</b> is a discontinuous signal that changes from one condition to one more condition in discrete steps.
Decibel	The standard unit used to express transmission gain or loss and relative power levels. Also written as dB.
Decoder	Processor in a video receiver that changes digital video data to analogue signals for replay on analogue monitors; or in some cases a software decoder, a program that decodes digital data for replay on the PC (decompression etc.).

D	Means...
Demodulate	To collect the information originally impressed on the radio wave.

E	Means...
Electromagnetic field	The field of force that an electrical current produces around the conductor through which it flows.
Electromagnetic Waves	A wave propagating as a periodic disturbance of the electrical and magnetic fields and having frequency in the electromagnetic spectrum; the means by which energy is transmitted from one area to one more area.
Elementary Stream (ES)	Elementary streams: These streams contain only one MPEG-2 video channel and no audio. Elementary streams are required if you intend to operate <b>Milestone</b> or a player that cannot operate with Transport streams.  You must be in RTSP mode to operate Elementary streams.
Encoder	A processor in a video transmitter which changes an analog video from a camera to digital data.

F	Means...
FEC	<b>Forward Error Correction</b> is a system of error control for data transmission, whereby the sender adds redundant data to its messages, also known as an <b>error-correction code</b> . This lets the receiver find and correct errors (inside some bound) without the need to ask the sender for additional data. The advantage of forward error correction is that a back-channel is not required, or that retransmission of data can often be prevented, at the cost of higher bandwidth requirements on average. FEC is thus applied in situations where retransmissions are relatively costly or impossible.
Firmware	Software which is installed directly on a device and is intended specially for that device and is used to control it.
FOV	<b>Field of View</b> - The field of view (also field of vision) is the angular quantity of the observable world that is seen at a given moment.
Fading	A periodic decrease in the received signal strength.

<b>F</b>	<b>Means...</b>
Frequency	The rate at which a procedure repeats itself. In radio communications, frequency is expressed in cycles for each second. Signals also have a property called wavelength, which is inversely in proportion to the frequency.
Frequency Modulation	Changing the frequency of a carrier wave, usually with an audio frequency, to send intelligence. Also called <b>FM</b> .
FPGA	<b>Field-Programmable Gate Array</b> - an integrated circuit designed to be configured by the customer or designer after manufacturing, hence "field-programmable".

<b>G</b>	<b>Means...</b>
GUI	<b>Graphical User Interface.</b>
GHz	<b>Gigahertz</b> - One gigahertz is equal to 1,000 megahertz (MHz) or 1,000,000,000 Hz.
Gain	The increase in signal strength that is produced by an amplifier.

<b>H</b>	<b>Means...</b>
Hertz	One cycle for every second.

<b>I</b>	<b>Means...</b>
IP Address	<b>Internet Protocol Address</b> - A unique numeric ID for a device in a network.
IR	<b>Infra-Red</b> - Infrared (IR) radiation is electromagnetic radiation whose wavelength is longer than that of visible light.
Impedance	The total opposition offered by a circuit or component to the flow of alternating current.

---

L	Means...
LOS and NLOS	<p><b>Line-of-sight</b> propagation refers to electro-magnetic radiation including light emissions moving in a straight line. The rays or waves are diffracted, refracted, reflected, or absorbed by atmosphere and obstructions with material and usually cannot move above the horizon or behind obstacles.</p> <p>NLOS is Non Line-of-sight.</p>
Load	A device that consumes electrical power.
Lux	The <b>lux</b> (symbol: <b>lx</b> ) is the SI unit of illuminance and luminous emittance. It is used in photometry as a measure of the apparent intensity of light hitting or passing through a surface.

M	Means...
MHz	<b>Megahertz</b> is the same as 1,000,000 Hz
mW	<b>Milliwatt</b> - The milliwatt (symbol: mW) is equal to one thousandth ( $10^{-3}$ ) of a watt.
MPEG	Moving Pictures Experts Group.
Modulation	<p>To change the output of a transmitter in amplitude, phase or frequency in accordance with the information to be transmitted.</p> <p>Data is superimposed on a carrier current or wave by means of a procedure called modulation. Signal modulation can be done in one of two ways: analogue and digital. In recent years, digital modulation has been getting more usual, while analogue modulation methods have been used less. There continues to be plenty of analogue signals around, but, and they will probably not become totally extinct.</p>
Multicast	Multicasting is sending data from a sender to multiple receivers where each receiver signals that they want to receive the data.

N	Means...
nm	A <b>nanometer</b> ; symbol <b>nm</b> is a unit of length in the metric system, equal to one billionth of a meter (i.e., $10^{-9}$ m or one millionth of a millimeter).

---

<b>N</b>	<b>Means...</b>
NMEA 0183	<b>NMEA 0183</b> is a combined electrical and data specification for communication between marine electronic devices such as echo sounder, sonar, anemometer, gyrocompass, autopilot, GPS receivers and many other types of instruments. It has been specified by, and is controlled by, the U.S.-based National Marine Electronics Association.
NTSC	National Television Systems Committee.
Noise	Random pulses of electromagnetic energy generated by lightning or electrical equipment.

<b>O</b>	<b>Means...</b>
Omnidirectional antenna	An antenna radiation pattern that shows the same radiation in all horizontal directions.
Oscillation	A periodic, repetitive movement or set of values (voltage, current, velocity).

<b>P</b>	<b>Means...</b>
PAL	Phase Alternate Line.
PIR	<b>Passive Infra-Red</b> sensor (PIR sensor) is an electronic device that measures infrared (IR) light radiating from objects in its field of view.
PTZ	<b>Pan, Tilt and Zoom</b> – PTZ is a usual description of controllable cameras.
Propagation	A phenomenon by which a wave moves from one point to a second point; the movement of electromagnetic waves through space or along a transmission line.

<b>Q</b>	<b>Means...</b>
QPSK	Quadrature Phase Shift Keying.

<b>R</b>	<b>Means...</b>
RF	<b>Radio Frequency.</b>

---

R	Means...
RTSP	<b>Real Time Streaming Protocol</b> (RTSP) is a network control protocol designed for operation in entertainment and communications systems to control streaming media servers. The protocol is used for establishing and controlling media sessions between end points. Clients of media servers issue VCR-like commands, such as play and pause, to let real-time control of playback of media files from the server.
Rx	<b>Receiver</b> , an electronic device that changes a radio signal from a transmitter into useful information.
Radiate	To transmit RF energy .
Radio Frequency	Frequency of electrical energy capable of propagation into space (usually above 20kHz). Also called RF.

S	Means...
SNR	<b>Signal to Noise Ratio</b> is an electrical engineering measurement specified as the ratio of a signal power to the noise power corrupting the signal.  Signal-to-noise ratio compares the level of a desired signal (such as music) to the level of background noise. The higher the ratio, the less obtrusive the background noise is.
Shannon Limit	The <b>Shannon limit</b> or <b>Shannon capacity</b> of a communications channel is the theoretical maximum information transfer rate of the channel, for a particular noise level.
Signal	In electronics, a signal is an electrical current or electromagnetic field used to send data from one area to a second area. The simplest type of signal is a direct current (DC) that is switched on and off; this is the principle by which the earliest telegraph worked. More complex signals consist of an alternating-current (AC) or electromagnetic carrier that contains one or more data streams.
Streaming	<b>Streaming</b> is the transmission of digital audio or video or the listening and viewing of such data without first storing it.

T	Means...
Tx	A <b>transmitter</b> is an electronic device which, usually with the aid of an antenna, propagates an electromagnetic signal such as radio, television, or other telecommunications.

<b>T</b>	<b>Means...</b>
TNC	The <b>TNC (threaded Neil-Concelman) connector</b> is a threaded version of the BNC connector. The connector has a 50 $\Omega$ impedance and operates best in the 0–11 GHz frequency spectrum.
Transport Stream (TS)	Transport streams: These streams can contain some MPEG-2 content channels and related audio. All the channels are multiplexed together, letting the receiver select which to play back.

<b>U</b>	<b>Means...</b>
UDP	<b>User Datagram Protocol (UDP)</b> Sometimes called fire and forget because there is no dialog between the sender and receiver. If the receiver does not receive a packet, the sender will not know. But, UDP is very satisfactory when there is a small risk of errors (like in your LAN), or when TCP can give "too late" delivery.
USB	Universal Serial Bus.
Unicast	Unicast is simply sending packets from one source to one destination. For example, from one web server to one (or each) person viewing a page on a web browser.

<b>V</b>	<b>Means...</b>
VHF	<b>Very High Frequency</b> – 30 MHz to 300 MHz
V	Volt.
Viterbi Decoder	A Viterbi decoder uses the Viterbi algorithm for decoding a bit stream that has been encoded using forward error correction based on a Convolutional code.

<b>W</b>	<b>Means...</b>
Watt	The <b>watt</b> (symbol: <b>W</b> ) is a derived unit of power in the International System of Units (SI). It measures rate of energy conversion. One watt is equivalent to 1 joule (J) of energy per second.
Waveform	Signal shape.

---

Waveguide

A specially formed hollow metal tube, usually rectangular in shape in cross section, used to connect a High Power amplifier to the antenna.

## **DOCUMENT DISCLAIMER**

**SPECIFICATIONS ARE SUBJECT TO CHANGE  
WITHOUT NOTICE.**

**WAVE CENTRAL LLC, IS NOT LIABLE FOR  
DAMAGES TO THIS OR ASSOCIATED  
EQUIPMENT CAUSED BY ANY ERRORS OR  
OMMISSIONS CONTAINED HEREIN. IF YOU  
HAVE QUESTIONS REGARDING THIS MANUAL  
CONTACT:**

**Wave Central LLC**

**99 Garden Parkway, Suite C., Carlisle, PA  
17013**

**+1 888 736 9283 [www.wavecentralrf.com](http://www.wavecentralrf.com)**